

A-1C

Single Drill, On Slab Unit

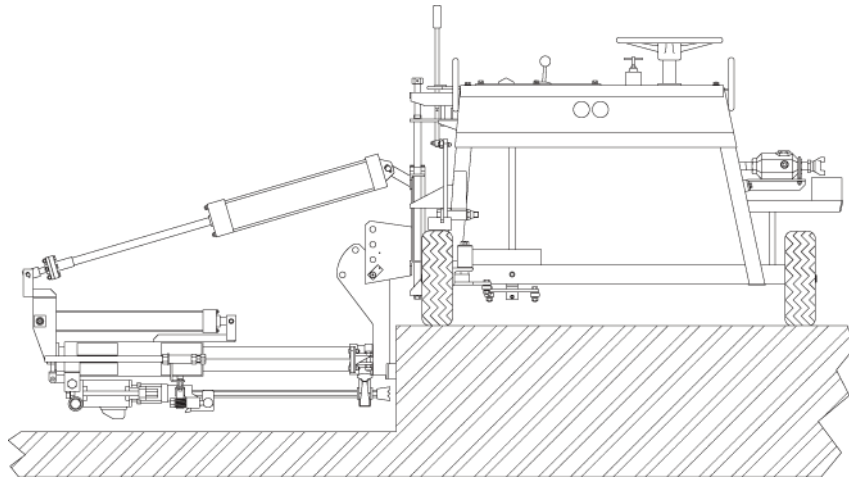

Three position drilling with 48" unit: Horizontal, Vertical and 35 degree stitch
Urethane filled tires
3-1 skew drilling standard
Adjustable drill height and depth
Dust collection is available

Model	A-1C-48	A-1C-36	A-1C-30	A-1C-24
Drill Steel Shank	.875" x 4.25" (22.2mm x 107.9mm)	.875" x 4.25" (22.2mm x 107.9mm)	.875" x 3.25" (22.2mm x 82.6mm)	.875" x 3.25" (22.2mm x 82.6mm)
Drill Steel Length U.C.	24"(61.0cm)	12"(30.5cm)	12"(30.5cm)	9"(22.9cm)
Drill Bit Diameter	.625" – 2.50" (15.9mm to 63.5mm)	.625" – 2.50" (15.9mm to 63.5mm)	.625" – 1.625" (15.9mm to 41.3mm)	.625" – 1.00" (15.9mm to 25.4mm)
*Maximum Drill Depth	18" (45.7cm)	10" (25.4cm)	10" (25.4cm)	7" (17.8cm)
Drill Distance From Top of Slab	2.5" – 12.75" (6.4cm to 32.4cm)	2.5" – 12.75" (6.4cm to 32.4cm)	2.5" – 12.75" (6.4cm to 32.4cm)	2.5" – 12.75" (6.4cm to 32.4cm)
Minimum Cutout Width	48" (121.9cm)	36" (91.4cm)	30" (76.2cm)	24" (61.0cm)
SCFM Required	92.2 (2.61 m ³ /min)	92.2 (2.61 m ³ /min)	75 (2.12 m ³ /min)	36 (1.02 m ³ /min)
PSIG Required	90 (0.62MPa)	90 (0.62MPa)	90 (0.62MPa)	90 (0.62MPa)
Weight	700lbs. (317.5kg)	665lbs. (301.6kg)	630lbs. (285.8kg)	605lbs. (274.4kg)

Specifications shown are standard. Variations to the standard are available.

***Based on 2 piece steel and bits. Whirlybits should be 1" (2.5cm) longer for maximum drilling depth.**