



MANUAL

HTC GL 270/400/450/550

Translation of manual in original language





The Greyline series

Contact Information

HTC Sweden AB
Box 69
SE-614 22 Söderköping - Sweden
Tel: +46 (0) 121-294 00
Fax: +46 (0) 121-152 12

You can find addresses for our retailers and service partners on our website:
www.htc-floorsystems.com

Always specify the model and serial number when asking questions about your product.

Trademarks

HTC is a trademark owned by HTC Sweden AB. Other names and products mentioned in this manual may be registered trademarks owned by the relevant companies.

© 2007 HTC Sweden AB. All rights reserved.

EC Declaration of conformity

Manufacturer:	HTC Sweden AB Box 69 SE-614 22 Söderköping Sweden +46 (0)121-29400
Type of equipment:	Grinding machine
Make:	HTC
Model:	HTC GL 270
Year of manufacture:	See machine name plate
Serial number:	See machine name plate

As the manufacturer, we hereby declare under our sole responsibility that the above product with serial numbers from 2010 onward conforms to the applicable regulations in directives MD 2006/42/EC, EMC 2004/108/EC and LVD 2006/95/EC. The following standards have been used as a basis: ISO 5349-1:2001, ISO 5349-2:2001, ISO 20643:2005, ISO 3741.

This product was CE-marked in 2010. The technical documentation is available from the manufacturer.

Original of the EC declaration of conformity (Swedish). Other languages are translations of the original of the EC declaration of conformity.

Söderköping, 12-05-2010



Peter Lundgren
Development Manager,
HTC Sweden AB



Kåre Kilgren
Product Manager,
HTC Sweden AB

EC Declaration of conformity

Manufacturer:	HTC Sweden AB Box 69 SE-614 22 Söderköping Sweden +46 (0)121-29400
Type of equipment:	Grinding machine
Make:	HTC
Model:	HTC GL 400
Year of manufacture:	See machine name plate
Serial number:	See machine name plate

As the manufacturer, we hereby declare under our sole responsibility that the above product with serial numbers from 2010 onward conforms to the applicable regulations in directives MD 2006/42/EC, EMC 2004/108/EC and LVD 2006/95/EC. The following standards have been used as a basis: ISO 5349-1:2001, ISO 5349-2:2001, ISO 20643:2005, ISO 3741.

This product was CE-marked in 2010. The technical documentation is available from the manufacturer.

Original of the EC declaration of conformity (Swedish). Other languages are translations of the original of the EC declaration of conformity.

Söderköping, 12-05-2010



Peter Lundgren
Development Manager,
HTC Sweden AB



Kåre Kilgren
Product Manager,
HTC Sweden AB

EC Declaration of conformity

Manufacturer:	HTC Sweden AB Box 69 SE-614 22 Söderköping Sweden +46 (0)121-29400
Type of equipment:	Grinding machine
Make:	HTC
Model:	HTC GL 450
Year of manufacture:	See machine name plate
Serial number:	See machine name plate

As the manufacturer, we hereby declare under our sole responsibility that the above product with serial numbers from 2010 onward conforms to the applicable regulations in directives MD 2006/42/EC, EMC 2004/108/EC and LVD 2006/95/EC. The following standards have been used as a basis: ISO 5349-1:2001, ISO 5349-2:2001, ISO 20643:2005, ISO 3741.

This product was CE-marked in 2010. The technical documentation is available from the manufacturer.

Original of the EC declaration of conformity (Swedish). Other languages are translations of the original of the EC declaration of conformity.

Söderköping, 12-05-2010



Peter Lundgren
Development Manager,
HTC Sweden AB



Kåre Kilgren
Product Manager,
HTC Sweden AB

EC Declaration of conformity

Manufacturer:	HTC Sweden AB Box 69 SE-614 22 Söderköping Sweden +46 (0)121-29400
Type of equipment:	Grinder
Make:	HTC
Model:	HTC GL 550
Year of manufacture:	See machine name plate
Serial number:	See machine name plate

As the manufacturer, we hereby declare under our sole responsibility that the above product with serial numbers from 2010 onward conforms to the applicable regulations in directives MD 2006/42/EC, EMC 2004/108/EC and LVD 2006/95/EC. The following standards have been used as a basis: ISO 5349-1:2001, ISO 5349-2:2001, ISO 20643:2005, ISO 3741.

This product was CE-marked in 2010. The technical documentation is available from the manufacturer.

Original of the EC declaration of conformity (Swedish). Other languages are translations of the original of the EC declaration of conformity.

Söderköping, 12-05-2010



Peter Lundgren
Development Manager,
HTC Sweden AB



Kåre Kilgren
Product Manager,
HTC Sweden AB

1	Introduction	1
1.1	General	1
1.2	Responsibility	1
1.3	Manual	1
1.3.1	Safety instructions – Explanation of symbols	1
1.4	Transportation	2
1.5	On delivery	2
1.6	Unpacking the machine	2
1.7	Machine name plate	3
1.8	Handling and storage	3
1.9	Vibration and noise	4
1.9.1	Hand and arm vibrations	4
1.9.2	HTC GL 270	4
1.9.3	HTC GL 400	4
1.9.4	HTC GL 450	4
1.9.5	HTC GL 550	5
1.9.6	Sound pressure level	5
2	Safety	6
2.1	General Information	6
2.2	Warnings	6
2.3	Notes	7
3	Machine description	9
3.1	General machine description	9
3.2	Description of controls – Control panel	11

4	Usage	13
4.1	General Information	13
4.2	Handle settings	14
4.3	Access to grinding tools	15
4.4	Fitting and replacing grinding tools	15
4.4.1	Fitting grinding tools	16
4.4.2	Changing grinding tools	17
4.5	Preparations for dry grinding	17
4.6	Separating and assembling the chassis and grinding head	18
4.6.1	HTC GL 270	18
4.6.2	HTC GL 400, GL 450 and GL 550	19
4.7	Operation	19
4.7.1	Starting and stopping the machine	20
4.7.2	Emergency stop switch	20
4.8	Making operation easier	20
4.9	Edge grinder kit (accessory for HTC GL 270)	21
4.9.1	Change to Edge Grinder Cover	21
4.9.2	Fitting the Edge Grinder Adapter	23
4.9.3	Positions for Edge Grinder Adapter	24
5	Maintenance and repairs	26
5.1	General Information	26
5.2	Cleaning	26
5.3	Daily	26
5.4	Every week	26
5.5	Every month (or 100 hours)	27
5.6	Repairs	27
5.7	Spare parts	27
6	Faultfinding	28
6.1	General Information	28
6.1.1	The machine will not start	28
6.1.2	The machine vibrates or wears the tool unevenly	28
6.1.3	The machine is grinding at an angle	28
6.1.4	The fuses trip frequently	28
6.1.5	The machine cannot cope	28
6.1.6	The machine grinds unevenly (only applies to HTC GL 450 and HTC GL 550)	29

7	Technical data	30
7.1	HTC GL 270	30
7.2	HTC GL 400	32
7.3	HTC GL 450	34
7.4	HTC GL 550	36
8	Environment	38
9	Warranty and CE marking	39
9.1	Warranty	39
9.2	CE marking	39

1 Introduction

1.1 General

The machine models in HTC's Greyline series are grinding machines that can be used to grind, strip and clean all types of floors. The area of application for the machine depends on the choice of tool.

Read the manual carefully, so you are totally familiar with the machine before you start to use it. Contact your local retailer for further information. For contact information, see Contact Information at the start of the manual.

1.2 Responsibility

Even though every effort has been made to make this manual as complete and accurate as possible, we bear no responsibility for incorrect or missing information. HTC reserves the right to change descriptions in this manual without giving prior notice.

This manual is protected by the Copyright Act and no part of it may be copied or used in any other way without the written approval of HTC.

1.3 Manual

In addition to the general functions, this manual deals with the areas of application and the maintenance of the grinder.

1.3.1 Safety instructions – Explanation of symbols

A number of symbols are used in the manual to highlight the most important sections, see below. In order to avoid both personal injury and material damage as far as possible, it is extremely important to read and understand the text next to these symbols particularly carefully. There are other symbols indicating practical tips. These are to help you use the machine in the easiest and most effective way.

The following symbols are used in the document to indicate where special attention is needed.



Warning!

This symbol means **Warning!** and indicates that incorrect use can result in material damage to the machine or accessories. If you see this symbol next to a section of text, you must be particularly careful when reading through the text and not carry out any stages of which you are unsure. This is to protect you and other users and to avoid damaging the machine or other equipment.

**Note!**

This symbol means **Note!** and indicates that material damage can occur if the machine or its accessories are used incorrectly. If you see this symbol next to a section of text, you must be particularly careful when reading through the text and not carry out any stages of which you are unsure. This is to avoid damage to the machine or other equipment.

**Tip!**

This symbol means **Tip!** and indicates that you can get tips and advice on ways to make operating your machine or associated equipment easier, and to avoid wear. When you see this symbol you should read the accompanying text to facilitate your work and increase the service life of the machine.

1.4 Transportation

The machine is best transported securely fastened to a pallet.

1.5 On delivery

The following items are included in the delivery. Contact your retailer if anything is missing.

- Grinding machine
- Manual disc
- Hammer EZ system
- Face spanner (not for HTC GL 270 and HTC GL 400)
- Lock spring tool holder
- Allen key
- Gloves
- HTC Cap

1.6 Unpacking the machine

**Warning!**

Read through the safety instructions and the manual carefully before use.

- Check carefully to see if the packaging or machine has been damaged during delivery. If there is any sign of damage, contact your retailer and report it. Report packaging damage to the transport company as well.
- Check that the delivery matches the order. If there are any discrepancies, contact your retailer.

1.7 Machine name plate

The machine name plate provides the following information. The model and serial number must be specified when ordering spare parts for the machine.

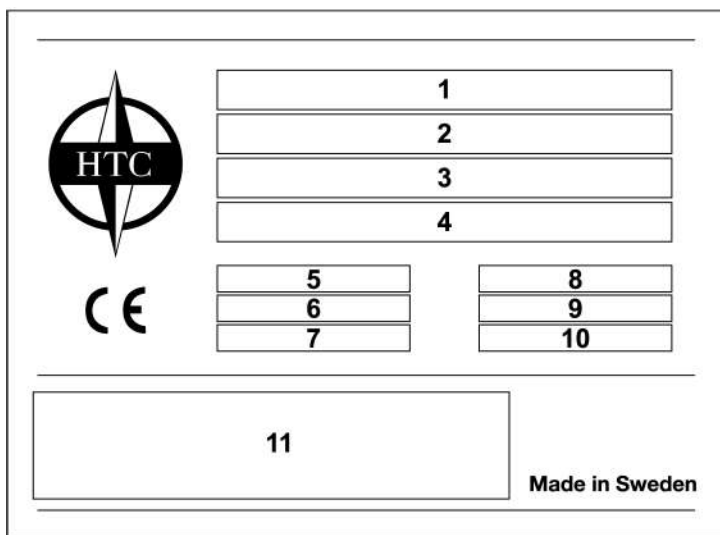

Figure 1-1. Machine name plate

1. Model
2. Model number
3. Serial number
4. Year of manufacture
5. Power (kW)
6. Voltage (V)
7. Current (A)
8. Frequency (Hz)
9. Rotational speed (r.p.m.)
10. Weight (kg)
11. Address field

1.8 Handling and storage

The machine should be stored in a dry, warm location when not in use. Otherwise it may become damaged by condensation and coldness.

1.9 Vibration and noise



Warning!

Always use ear muffs when using the machine.

1.9.1 Hand and arm vibrations

Hand and arm weighted vibration level [m/s^2] for HTC GL 550 HTC GL 450 HTC GL 400 HTC GL 270 have been measured with equipment approved according to ISO 5349-1:2001. The measurement uncertainty for the measurement apparatus has been measured as +/- 2%.

The machine has been tested in accordance with ISO 5349-2:2001 and ISO 20643:2005 in order to identify the operations that contribute to the most frequent vibration exposures. At vibration levels $> 2.5 m/s^2$, the exposure time should be limited in accordance with the table below. For vibration levels $> 5 m/s^2$, immediate measures should be taken by the employer to ensure that the exposure time does not exceed the time specified in the table below.

1.9.2 HTC GL 270

Identified work conditions	Measured values [m/s^2]	Daily permitted exposure (number of hours)
Grinding/polishing	2,43	Unrestricted
Floor preparation (T-rex)	9,37	2,28

1.9.3 HTC GL 400

Identified work conditions	Measured values [m/s^2]	Daily permitted exposure (number of hours)
Grinding/polishing	2,77	Unrestricted
Floor preparation (T-rex)	4,83	8,56

1.9.4 HTC GL 450

Identified work conditions	Measured values [m/s^2]	Daily permitted exposure (number of hours)
Grinding/polishing	1,16	Unrestricted
Floor preparation (T-rex)	2,35	Unrestricted

1.9.5 HTC GL 550

Identified work conditions	Measured values [m/s ²]	Daily permitted exposure (number of hours)
Grinding/polishing	2,5	Unrestricted
Floor preparation (T-rex)	3,87	13,4

1.9.6 Sound pressure level

This machine has been tested for noise in accordance with ISO 3741. For information on sound pressure levels, see the table in chapter [Technical data, page 30](#).

2 Safety

2.1 General Information

This chapter contains all the warnings and notes that should be considered for HTC GL 270, HTC GL 400, HTC GL 450, HTC GL 550.

2.2 Warnings

**Warning!**

The machine may only be used or repaired by personnel who have received the requisite theoretical and practical training and who have read the user manual.

**Warning!**

Never use the machine in an environment with a risk of explosion or fire. Familiarise yourself with the fire-protection instructions for the working area and follow them.

**Warning!**

Secure the area around the working area. No unauthorised persons should be allowed within a 15-metre radius of the machine. If a loose object were to catch under the grinding head, this could be flung out and cause personal injury.

**Warning!**

Use protective equipment such as safety shoes, safety goggles, protective gloves, breathing mask and ear muffs.

**Warning!**

The machine must only be started with the grinding head down. The rotating disc must be touching the floor and the correct tool must be fitted.

**Warning!**

Read through the safety instructions and the manual carefully before use.

**Warning!**

Always use ear muffs when using the machine.

**Warning!**

During grinding, the tools become very hot. Tip the machine back and allow it to stand for a short while. Use protective gloves when removing the tools.

**Warning!**

Disconnect the electrical supply, when changing tools or repairing the machine.



Warning!

The machine must only be used and moved on level surfaces. There is a risk of crushing if the machine starts to roll.



Warning!

Connect the machine to an earth fault breaker.



Warning!

Do not clean the machine using a high-pressure washer. Otherwise moisture may penetrate electrical elements and damage the machine's drive system.



Warning!

Always ensure that the machine's connection cable is hanging freely without any tensile loading. Otherwise, the cable, coupling socket and plug may be damaged, which can cause both physical damage and personal injury.



Warning!

Always ensure that the machine's handle is in the upright position when the machine is tipped to enable access beneath the grinding head. Otherwise, there is a risk that the machine could fall back and cause personal injury.



Warning!

The lifting handles on the motor are intended for lifting the grinding head, when it is separated from the chassis, and then only for short, low lifts, e.g. into the boot of a car. The lifting handles are not to be used for lifting the complete machine.

2.3 Notes



Note!

The machine may only be used to grind, strip and clean floor coverings and other materials that are stated in this manual or materials that are recommended by HTC.













Note!

Only original tools and spare parts from HTC may be used for the machine. Otherwise neither the CE marking nor the warranty will be valid.



Note!

For the CE marking to be valid, the instructions in this manual must be followed.

-  **Note!**
The machine may only be lifted using the lifting eye on the chassis in accordance with the relevant instructions.
-  **Note!**
Make sure that the floating cover can move freely within its movement margins and that the cover rests on the floor before starting the machine.
-  **Note!**
The machine should be stored in a dry, warm (plus degrees) location when not in use.
-  **Note!**
If the machine is stored in a cold (minus degrees) location, it must be placed in a warm (plus degrees) location for at least two hours before use.
-  **Note!**
The appropriated dust extractor must be used when dry grinding. Contact HTC for model recommendation.
-  **Note!**
The dust extractor's suction hose must be connected to the appropriate socket on the machine. Adjust the dust extractor to match the grinder's capacity.
-  **Note!**
Do not use the emergency stop switch to stop the machine, except in emergencies.
-  **Note!**
As long as the emergency stop switch is pressed in, the machine cannot be started. Reset by turning the switch 45° clockwise so that it pops out again. The machine can then be restarted.
-  **Note!**
Check that all the parts are correctly attached and that all the screws are tightened properly before the machine is started.
-  **Note!**
After removing glue, always lift the grinding heads so they do not stick to the floor and damage machine components or the floor when the machine is restarted.

3 Machine description

3.1 General machine description

The machine is constructed from a number of main components, see *Figure 3-1, page 10* and *Figure 3-2, page 11*. For each machine model in the series, there are a number of different motor alternatives, see tables in *Technical data, page 30*.

The machine is based on a wheeled chassis. The motor with the rotating grinding unit is mounted on the lower part of the chassis enabling some movement between the chassis and the motor assembly.

The machines in the series are equipped with a lifting eye on the chassis and two lifting handles on the grinding head, see *Figure 3-1, page 10*. The lifting eye is intended for lifting the complete machine. The lifting handles are intended for lifting the grinding head, when it is separated from the chassis, and then only for short, low lifts, e.g. into the boot of a car. The lifting handles are not to be used for lifting the complete machine.

The handle can be placed in a number of different working positions by loosening the locking mechanism for adjusting the handle (see *Figure 3-2, page 11*) and moving the handle up and down to the desired working height. The angle of the handle (see *Figure 3-2, page 11*) can also be adjusted to obtain the best ergonomics. The handle can also be placed in the upright position, which must be used when the machine is tipped to enable access under the grinding head, e.g. when changing tools.

The machine has a connection for an external suction hose, which is used during dry grinding.

The machine can be easily equipped with a large number of tools, depending on the material to be ground. For the different tools, see HTC's Product Catalogue under the Grinding Guide tab.

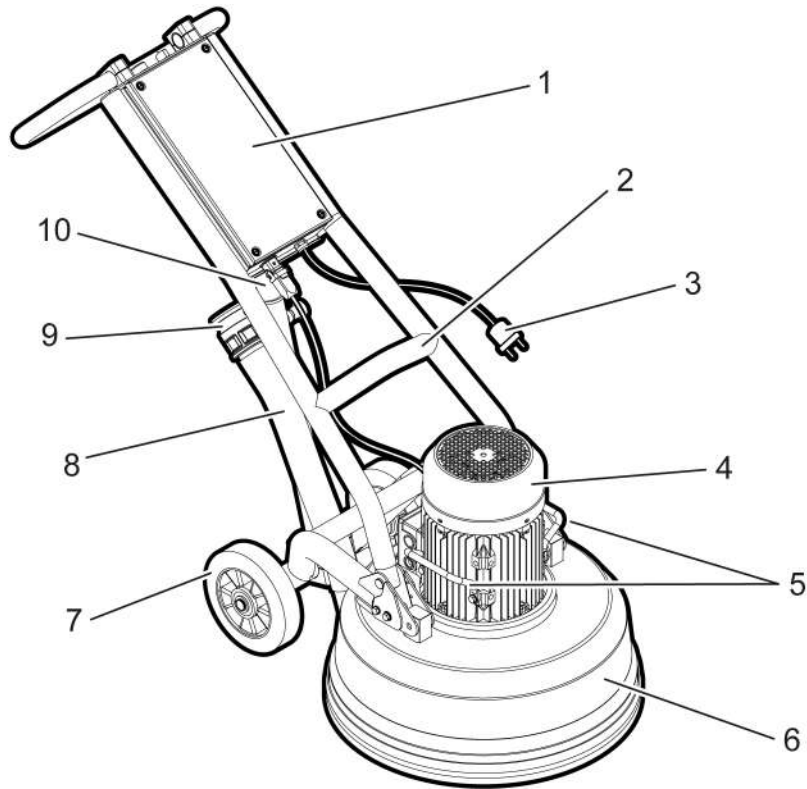

Figure 3-1. The front of the machine

1. Control cabinet
2. Lifting eye for the machine
3. Plug
4. Motor
5. Lifting handles for grinding head
6. Floating grinding cover
7. Wheels
8. Suction hose
9. Connection for vacuum
10. Quick release coupling motor cable

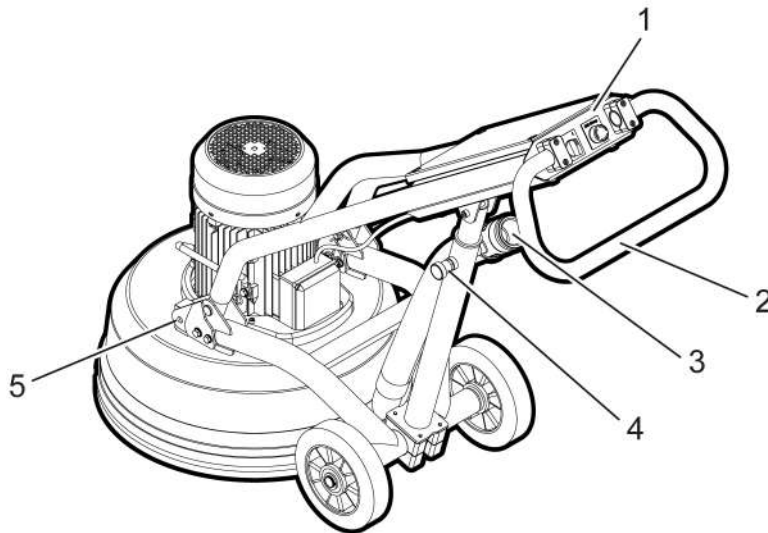

Figure 3-2. The machine's rear

1. Control panel
2. Adjustable handle
3. Connection for vacuum
4. Locking mechanism for handle adjustment
5. Locking bolts/quick release grinding head

3.2 Description of controls – Control panel

The picture below shows the machine's control panel:

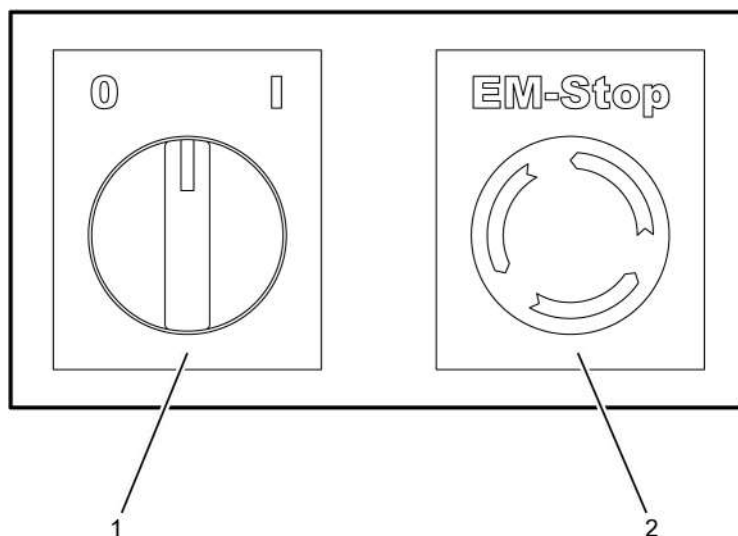

Figure 3-3. Control Panel

1. **O/I-** Start/stop the machine. Turn the knob to "I" to start the machine. Hold the knob in start position "I" for ca. 1-2 seconds. Turn the knob to "O" to switch off the machine.

2. **EM-Stop** - Emergency stop switch: Press the switch in an emergency to cut the power to the machine. Reset the emergency stop switch by turning it 45° clockwise.

4 Usage

4.1 General Information

The following section describes how to change tools and how to operate the grinding machine. This section does not deal with the technical aspects of grinding, such as selection of grinding tools, etc. For choice of tools, see HTC's Product Catalogue under the Grinding Guide tab.



Warning!

The machine may only be used or repaired by personnel who have received the requisite theoretical and practical training and who have read the user manual.



Warning!

Never use the machine in an environment with a risk of explosion or fire. Familiarise yourself with the fire-protection instructions for the working area and follow them.



Warning!

Secure the area around the working area. No unauthorised persons should be allowed within a 15-metre radius of the machine. If a loose object were to catch under the grinding head, this could be flung out and cause personal injury.



Warning!

Use protective equipment such as safety shoes, safety goggles, protective gloves, breathing mask and ear muffs.



Warning!

The machine must only be started with the grinding head down. The rotating disc must be touching the floor and the correct tool must be fitted.



Warning!

The machine must only be used and moved on level surfaces. There is a risk of crushing if the machine starts to roll.



Warning!

The lifting handles on the motor are intended for lifting the grinding head, when it is separated from the chassis, and then only for short, low lifts, e.g. into the boot of a car. The lifting handles are not to be used for lifting the complete machine.

**Warning!**

Always ensure that the machine's connection cable is hanging freely without any tensile loading. Otherwise, the cable, coupling socket and plug may be damaged, which can cause both physical damage and personal injury.

**Warning!**

Connect the machine to an earth fault breaker.

**Tip!**

Check the minimum recommended cable area before using an extension cord. You will find the recommended cable area under *Technical data, page 30*.

4.2 Handle settings

The picture below shows the handle positions on the machine.

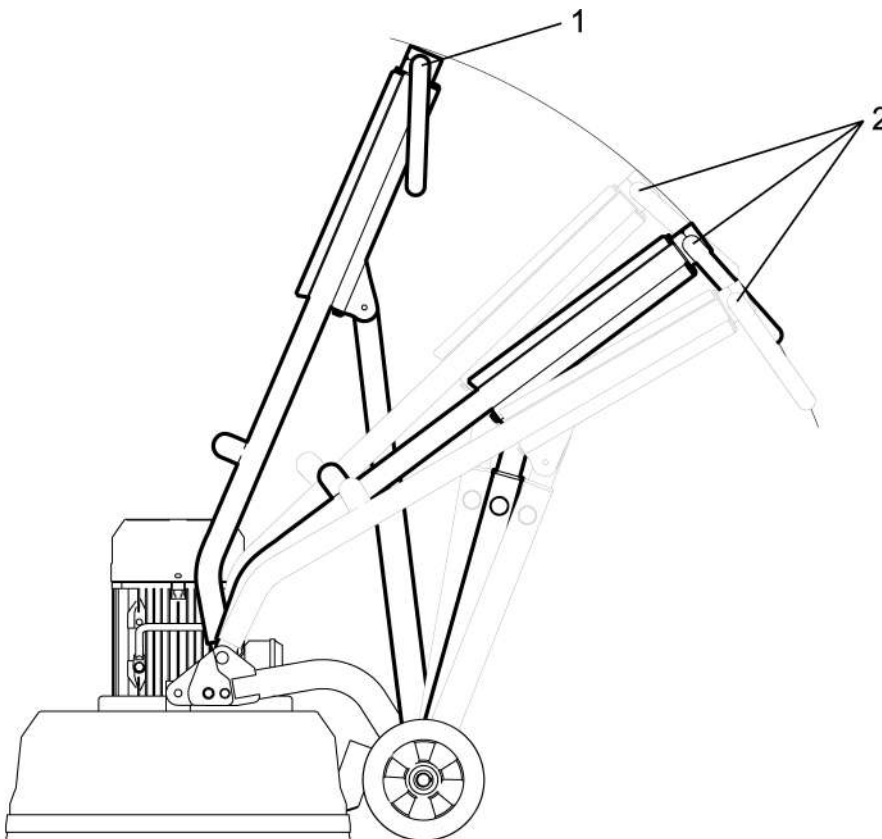

Figure 4-1. Handle settings

1. Upright position - used when tipping the machine to ease access to the underside of the grinding head, e.g. when changing tools
2. Working position - the working height can be adjusted to one of several positions with the machine's adjustable handle



Warning!

Always ensure that the machine's handle is in the upright position when the machine is tipped to enable access beneath the grinding head. Otherwise, there is a risk that the machine could fall back and cause personal injury.

- Adjust and lock the handle in the desired position, using the locking mechanism, see *Figure 3-2, page 11*.
- Adjust the handle to the desired angle to achieve the best ergonomics, see *Figure 3-2, page 11*.

4.3 Access to grinding tools



Warning!

During grinding, the tools become very hot. Tip the machine back and allow it to stand for a short while. Use protective gloves when removing the tools.



Warning!

Disconnect the electrical supply, when changing tools or repairing the machine.

1. Set the handle to the upright position - see *Figure 4-1, page 14*
2. Tip the machine backwards so that it rests on the ground.

4.4 Fitting and replacing grinding tools



Warning!

Disconnect the electrical supply, when changing tools or repairing the machine.



Warning!

During grinding, the tools become very hot. Tip the machine back and allow it to stand for a short while. Use protective gloves when removing the tools.



Note!

Check that the motor's direction of rotation agrees with the direction arrow on the motor. This is to guarantee the correct use of the T-Rex A grinding tool.

4.4.1 Fitting grinding tools

1. Slide the grinding tool diagonally from above down into the appropriate guide slot on the tool holder. Then push the tool fully into the guide slot, see [Figure 4-2, page 16](#).

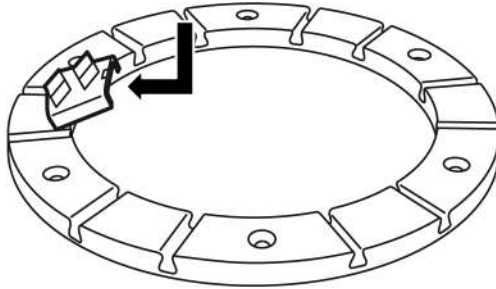

Figure 4-2. Fitting grinding tools

2. Lock the grinding tool into the tool holder by giving it a few light taps with a rubber hammer - see [Figure 4-3, page 16](#).

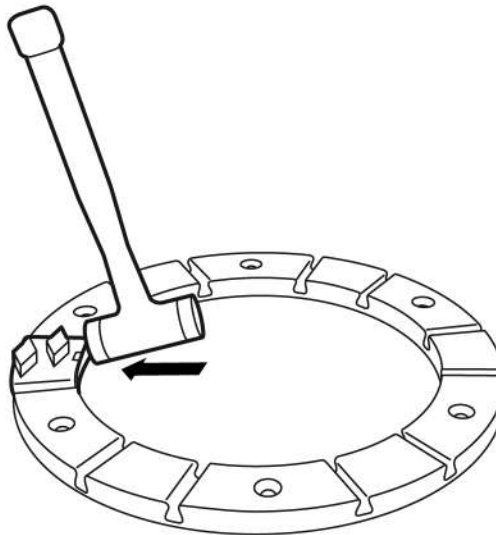

Figure 4-3. Locking grinding tools

4.4.2 Changing grinding tools

1. Remove the grinding tool by giving it a few light taps with a rubber hammer so the locking mechanism releases, see [Figure 4-4, page 17](#). Then draw the tool up out of the guide slot.

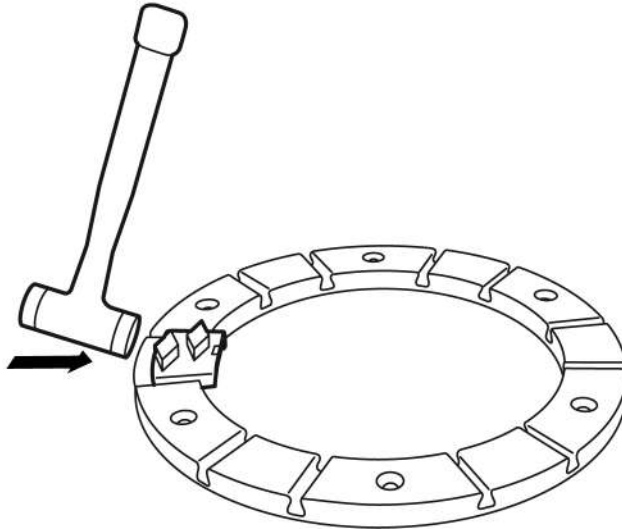

Figure 4-4. Removing grinding tools

2. Slide the grinding tool diagonally, from above, down into the appropriate guide slot on the tool holder, see [Figure 4-2, page 16](#). Then push the tool fully into the guide slot.
3. Lock the grinding tool into the tool holder by giving it a few light taps with a rubber hammer - see [Figure 4-3, page 16](#).

4.5 Preparations for dry grinding



Note!

Make sure that the floating cover can move freely within its movement margins and that the cover rests on the floor before starting the machine.

1. Connect a dust extractor to the machine. For dust extractor models, see under the Suction System tab in the HTC Product Catalogue.



Note!

The dust extractor's suction hose must be connected to the appropriate socket on the machine. Adjust the dust extractor to match the grinder's capacity.

2. Inspect the floor carefully and remove any objects sticking up, such as reinforcement rods or bolts, and any debris that could get caught in the machine.

3. Attach the appropriate tool to the machine.
4. Set the handle to the desired height and with the desired angle for the best working position.

4.6 Separating and assembling the chassis and grinding head

The machine can be split into two parts; the chassis and the grinding head. This can be useful, for example when there is a need to pack the machine better for transport or during maintenance and repair of one of the machine's components.

- Hold the chassis securely, when the locking bolts and the quick release are loosened, to prevent the chassis from falling to the ground and possibly causing material damage or personal injury.



Tip!

Ask someone to hold the chassis while you loosen the locking bolts and the quick release.

4.6.1 HTC GL 270

Remove the grinding head from the chassis as follows:

1. Undo the quick release coupling for the motor cable, see *Figure 3-1, page 10*.
2. Remove the suction hose from the grinding cover or from the vacuum connection, see *Figure 3-1, page 10* and *Figure 3-2, page 11*.
3. Remove the safety pins from the quick release, see *Figure 3-2, page 11*.
4. Place the red locking hooks in each quick release in the upright position.
5. Slowly pull the chassis back from the grinding head.

Attach the grinding head to the chassis as follows:

1. Push the chassis's fastener into the quick release and make sure that the red locking hooks drop down, so the safety pins can be put in place.
2. Replace the vacuum hose and connect the quick release coupling to the motor. The machine is now ready to use.



Tip!

Always make sure that the safety pins are fixed correctly when transporting the machine.

4.6.2 HTC GL 400, GL 450 and GL 550

Remove the grinding head from the chassis as follows:

1. Undo the quick release coupling for the motor cable, see *Figure 3-1, page 10*.
2. Remove the suction hose from the grinding cover or from the vacuum connection, see *Figure 3-1, page 10* and *Figure 3-2, page 11*.
3. Remove the safety pins from the locking bolts, see *Figure 3-2, page 11*.
4. Pull the locking bolts out of the fastenings on both sides of the grinding head.



Tip!

Ask someone to hold the chassis while you loosen the locking bolts and the quick release.

5. Slowly pull the chassis back from the grinding head.

Attach the grinding head to the chassis as follows:

1. Push the chassis in towards the grinding head's lifting eye.
2. Push the locking bolts in on both sides of the grinding head, making sure that they go all the way through, and attach the locking pins.
3. Replace the vacuum hose and connect the quick release coupling to the motor. The machine is now ready to use.

4.7 Operation

The machine's functions can be controlled using the control panel - see *Figure 3-3, page 11*.

During operation, the operator pushes the grinder forwards over the floor surface.

4.7.1 Starting and stopping the machine

1. Connect the electricity supply by plugging in the plug.
2. Make sure the emergency stop switch is reset.
3. Turn the Power knob to "I" to start the machine. Hold the knob in the start position "I" for ca 1-2 seconds.
4. Turn the Power knob to "O" to switch off the machine.

4.7.2 Emergency stop switch

The emergency stop switch must only be used in an emergency.

When the switch is pressed, all electrically-powered equipment on the machine are turned off.

**Note!**

Do not use the emergency stop switch to stop the machine, except in emergencies.

**Note!**

As long as the emergency stop switch is pressed in, the machine cannot be started. Reset by turning the switch 45° clockwise so that it pops out again. The machine can then be restarted.

**Note!**

Do not hold the knob in start position "I" longer than is needed to start the machine. Holding the knob in start position "I" for longer will damage the machine.

4.8 Making operation easier

In order to keep the suction hose for the dust extractor and the power cable out of the working area and/or path of the machine, the hose and cable can be arranged as shown in the picture below.

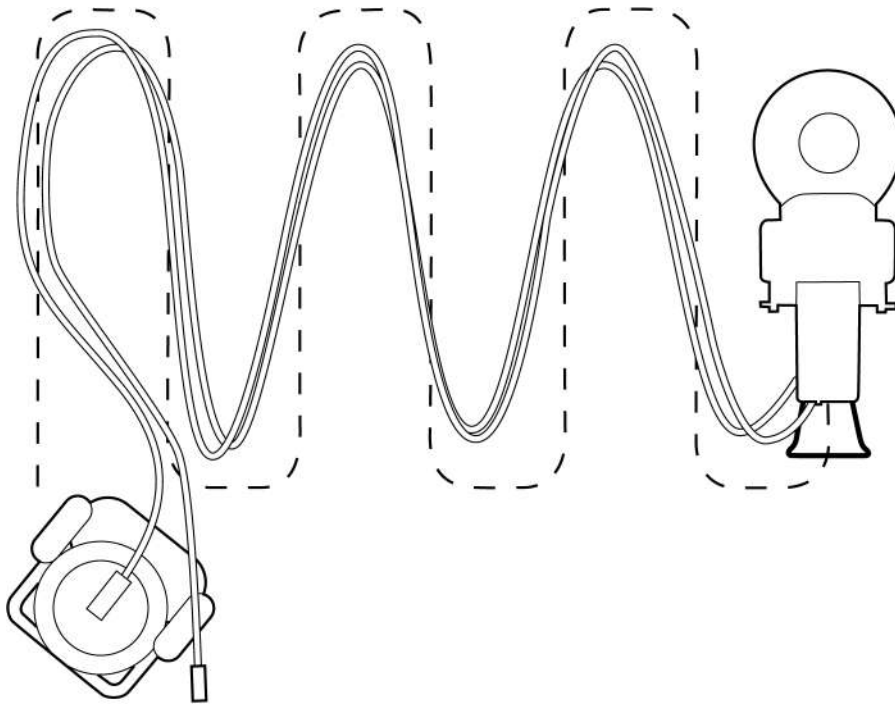

Figure 4-5. Making operation easier



Tip!

By arranging the hose and cable as shown in the picture, you avoid disruptive stoppages caused by having to re-position the cable and hose.

4.9 Edge grinder kit (accessory for HTC GL 270)

By attaching the edge grinder kit accessory to the HTC GL 270, there is the option to use the machine as an edge grinding machine. The attachment is done in a few easy steps, and with just a few parts, but it provides increased flexibility in the use of the machine. The edge grinder kit makes it possible to grind edges and corners effectively from different directions.

Follow the instructions under Change to Edge Grinder Cover, Attachment of Edge Grinder Adapter, and Positions for Edge Grinder Adapter when attaching the edge grinder kit.

4.9.1 Change to Edge Grinder Cover

Perform the change in the order below. The numbers in [Figure 4-6, page 22](#) correspond to the numbers in the procedure below:

1. Loosen the lower screw and remove the tool holder.
2. Remove the four motor bolts.

3. Remove the machine's grinding cover.
4. Replace the grinding cover with the edge grinding cover and assemble all of the parts.

Note! Check that all the parts are correctly attached and that all the screws are tightened properly before the machine is started.

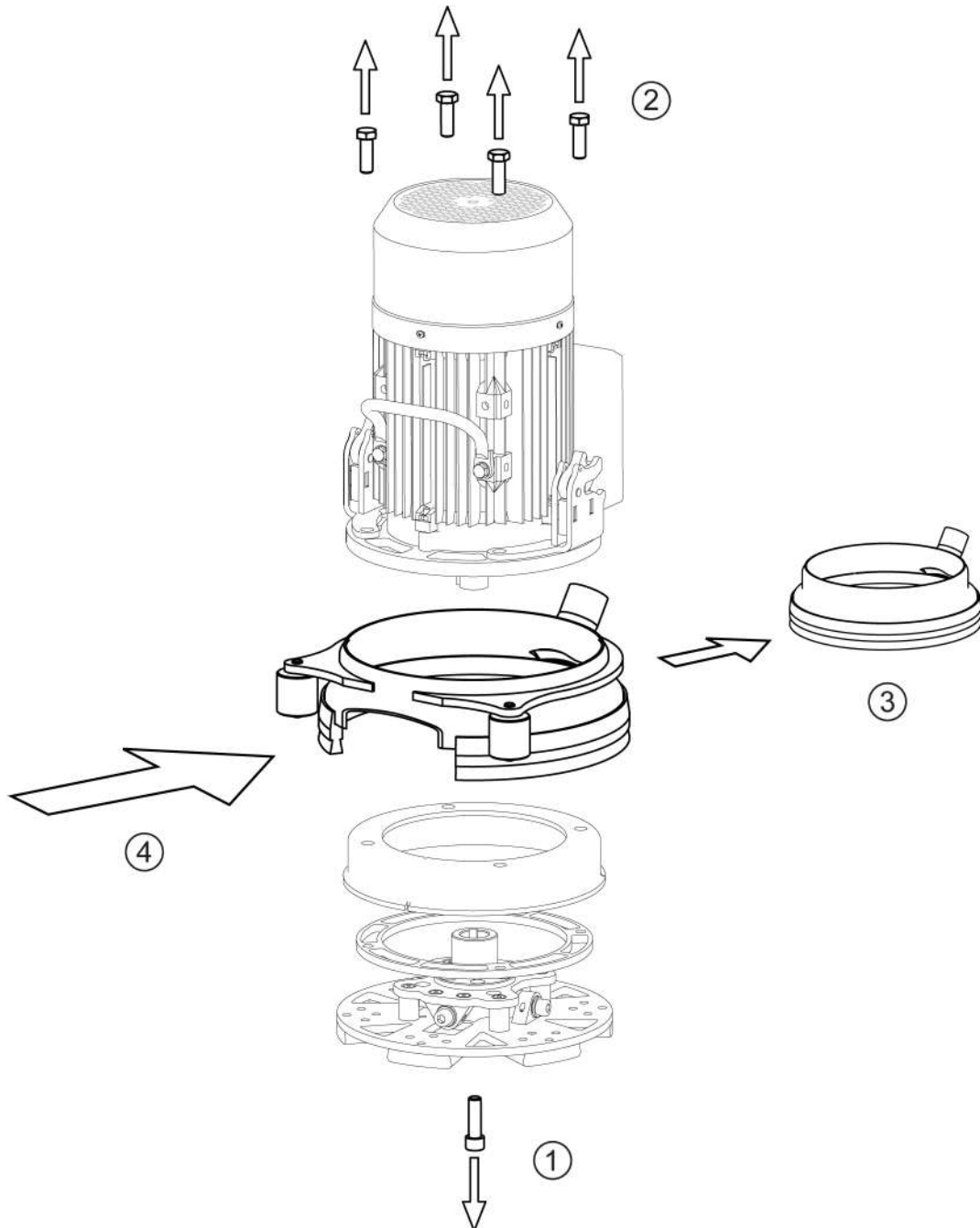

Figure 4-6. Removal of grinding cover - fitting the edge grinding cover

4.9.2 Fitting the Edge Grinder Adapter

Attach the edge grinding adapter in the order given below. The numbers in *Figure 4-7, page 23* and *Figure 4-8, page 23* correspond to the numbers in the procedure below:

1. Remove the locking bolts from the chassis.
2. Insert the edge grinder adapter's lower attachment into the chassis.
3. Fold the edge grinder adapter into the chassis.
4. Lock the edge grinder adapter in the chassis using the new, longer, locking bolts that are enclosed with the edge grinder kit.
5. Lock the locking bolts with the safety pins.

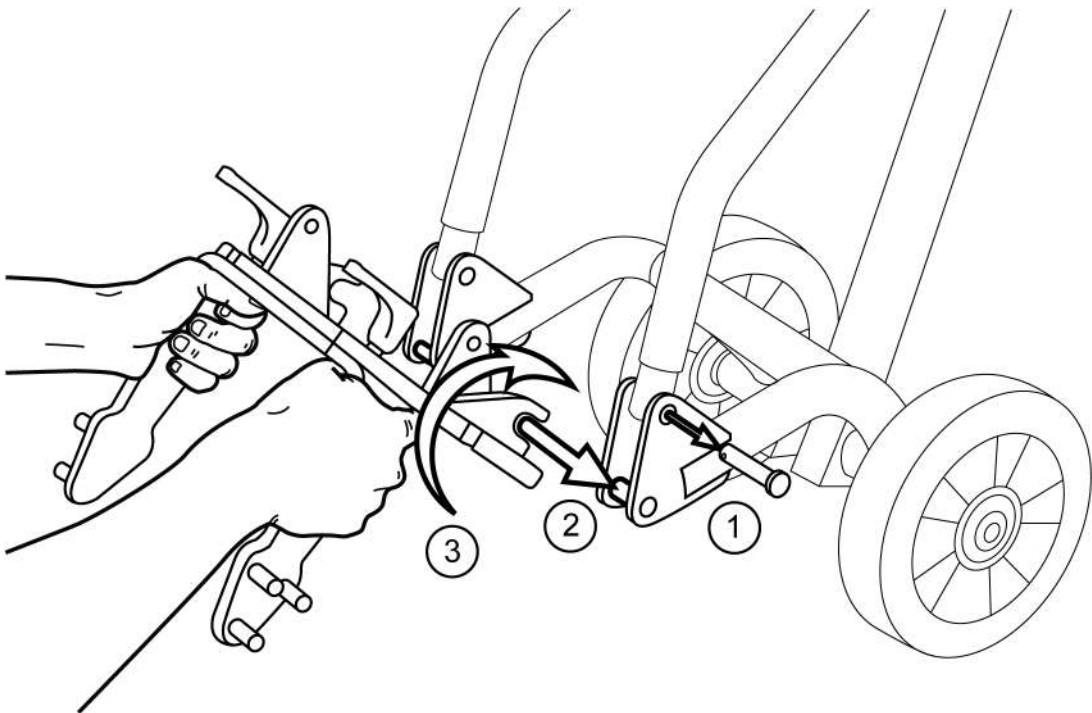

Figure 4-7. Attaching the edge grinder adapter, steps 1 - 3

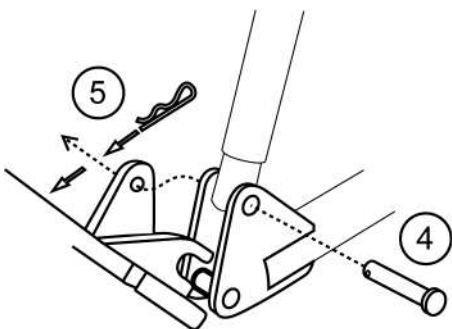

Figure 4-8. Attaching the edge grinder adapter, steps 4 - 5

4.9.3 Positions for Edge Grinder Adapter

The grinding head can be attached in the right, left or centre position on the edge grinder adapter. This gives the option to grind edges and corners effectively from different directions.

Change between left and right position:

- Detach the grinding head from the edge grinder adapter.
- Slightly loosen the locking knob, see position 1 in *Figure 4-9, page 24*.
- Turn the hoop 180°, see position 2 in *Figure 4-9, page 24*. Then firmly lock the locking knob (*Figure 4-10, page 24*).

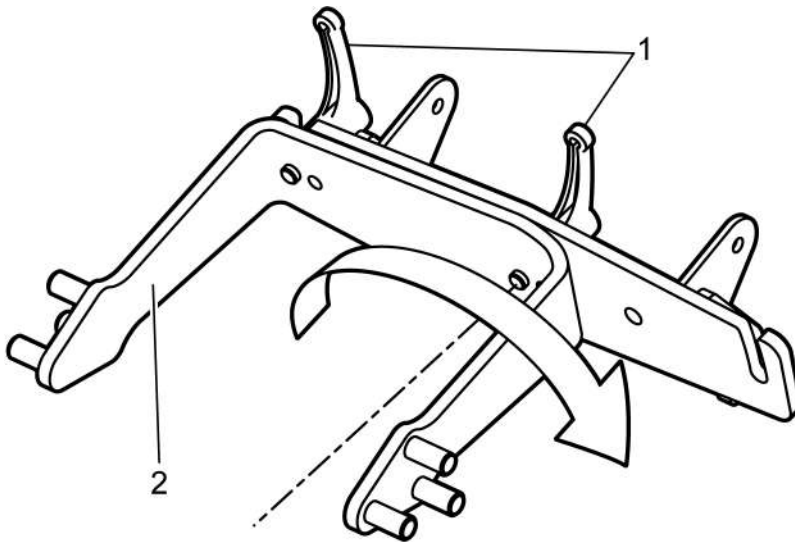

Figure 4-9. Turning the hoop, left - right

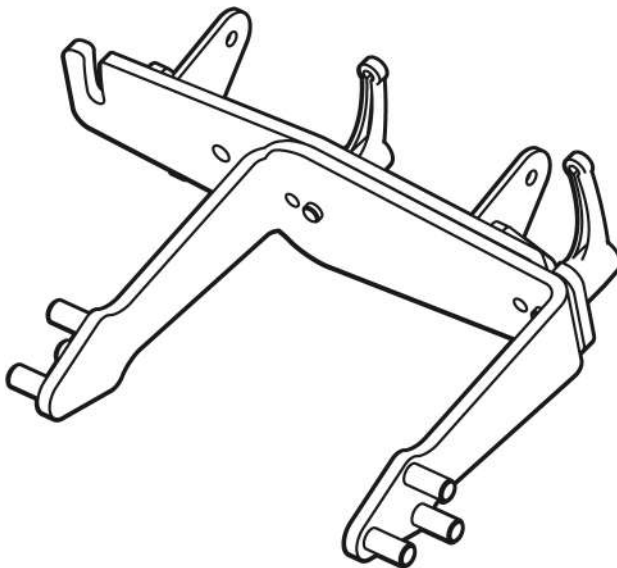

Figure 4-10. Hoop in right-hand position

Place in the centre position (*Figure 4-11, page 25*):

- Screw the locking knob out completely. Then firmly lock the locking knob.

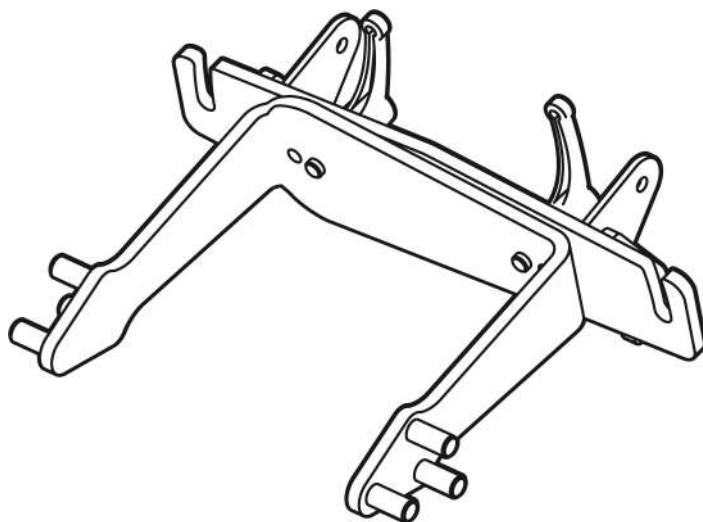

Figure 4-11. Hoop in the centre position

5 Maintenance and repairs

5.1 General Information

We recommend regular inspections of all seals.

**Warning!**

Disconnect the electrical supply, when changing tools or repairing the machine.

**Warning!**

Use protective equipment such as safety shoes, safety goggles, protective gloves, breathing mask and ear muffs.

5.2 Cleaning

**Warning!**

Do not clean the machine using a high-pressure washer. Otherwise moisture may penetrate electrical elements and damage the machine's drive system.

- Always clean the machine after use with a damp sponge or cloth.

5.3 Daily

- Check for wear to the grinding tool – abnormal or uneven wear may indicate a damaged grinding holder.
- Check the tool holder and grinding holder to ensure that no damage or cracks have arisen. Replace the parts if there is any damage.
- Check that the brush strip on the grinding cover is not damaged and that it is correctly attached.

5.4 Every week

- Wash the machine.
- Check the grinding holders. Remove the tools and run the machine in the air. If the grinding holders oscillate or wobble significantly, they are damaged.

**Tip!**

Recondition all the grinding holders at the same time.

5.5 Every month (or 100 hours)

- Check that all screws and joints are tightened and correctly attached.
- Check that the grinding cover is whole and undamaged.
- Check the upper belt and replace if necessary. See under *The machine grinds unevenly (only applies to HTC GL 450 and HTC GL 550), page 29* for instructions on how to perform the check.
- Check the seals on the shafts on which the upper belt runs and replace if necessary, (only applies to HTC GL 450 and HTC GL 550).
- Scrape and vacuum-clean the parts shielded by the grinding cover.
- Test run and listen for any dissonance from the bearings.

5.6 Repairs

Any repairs that may be required must be carried out by a HTC Service Centre, which has trained service personnel and uses HTC original parts and accessories. Contact your retailer if your machine requires servicing. For contact information, see Contact Information at the start of the manual.

5.7 Spare parts

To ensure rapid delivery of spare parts, always specify the model, the machine's serial number and the spare part number when ordering. Information on the model and serial number can be found on the machine's name plate.

Information on spare part numbers can be found in the machine's spare parts list which is available to read or print out from the accompanying digital media or HTC's website:

www.htc-floorsystems.com

Only original tools and original spare parts from HTC may be used. Otherwise neither the CE marking nor the warranty will be valid.

6 Faultfinding

6.1 General Information

This chapter describes faults that may occur and how to deal with them. If the fault cannot be dealt with, or if there are other faults, contact your nearest retailer. See Contact Information at the front of the manual.

6.1.1 The machine will not start

- Check if the emergency stop switch on the control panel is pressed. Reset the switch by turning it 45° clockwise.
- Check that the connection to the mains supply is correct.
- Check that the motor cable is attached correctly.
- Check that the fuses or earth fault breaker on the mains supply have not been tripped.

6.1.2 The machine vibrates or wears the tool unevenly

- Recondition the grinding holder by replacing the sleeves and vibration damper.
- Check that there is movement between the chassis and grinding head.

6.1.3 The machine is grinding at an angle

- Recondition the grinding holder. See under *The machine vibrates or wears the tool unevenly, page 28*.
- Check that there is movement between the chassis and grinding head.

6.1.4 The fuses trip frequently

- The load is too high on the distribution box to which the machine is connected. Try changing socket.
- Check the tools. Ensure that the correct tools are used, that they are in working order and that they are correctly fitted.

6.1.5 The machine cannot cope

- Heavy load. Press the handle down slightly so that the grinding head eases slightly away from the surface being ground.
- Ensure the mains supply quality by checking that there is full voltage on the motor's phase/phases.

- Sticky coating on the surface being ground. Run half of the machine on the surface to be cleaned and half on the clean surface. This removes any residue from the tools.
- Check the tools. Ensure that the correct tools are used, that they are in working order and that they are correctly fitted.
- Voltage drop. Check that the cable area complies with HTC's recommendations.



Tip!

Check the minimum recommended cable area before using an extension cord. You will find the recommended cable area under *Technical data, page 30*.

6.1.6 The machine grinds unevenly (only applies to HTC GL 450 and HTC GL 550)



Note!

The machine must not be connected to the mains supply when carrying out the points below.

- Check that the upper belt is undamaged by turning the grinding holders a few turns. The grinding head must rotate in the opposite direction to the grinding holders.
- Check that the inner belt is undamaged by turning one of the grinding holders a few turns. The other grinding holders must then rotate in the same direction as the grinding holder that is being turned.

7 Technical data

The tables and pictures below show the technical data and dimensions for the respective machine.

7.1 HTC GL 270

	HTC GL 270 110V 50Hz GB	HTC GL 270 110V 60Hz US	HTC GL 270 230V 50Hz EU	HTC GL 270 230V 60Hz US
Part number	113137	113121	113120	113154
Total machine weight	53 kg	53 kg	53 kg	53 kg
Weight, grinding head	37 kg	37 kg	37 kg	37 kg
Chassis weight	16 kg	16 kg	16 kg	16 kg
Grinding pressure	34 kg	34 kg	34 kg	34 kg
Grinding diameter	270 mm	270 mm	270 mm	270 mm
Grinding discs	1 x 270 mm	1 x 270 mm	1 x 270 mm	1 x 270 mm
Motor	1.5 kW	1.5 kW	1.5 kW	1.5 kW
Tension	1 x 110 V	1 x 110 V	1 x 230 V	1 x 230 V
Current	17.58 A	17.58 A	8.31 A	8.31 A
Rec. minimum cable area	2.5 mm ²	2.5 mm ²	1.5 mm ²	1.5 mm ²
Frequency	50 Hz	60 Hz	50 Hz	60 Hz
Rotational speed, grinding discs	960 r.p.m.	1152 r.p.m.	960 r.p.m.	1152 r.p.m.
Storage temperature	-20...+40 °C	-20...+40 °C	-20...+40 °C	-20...+40 °C
Working temperature	-20...+40 °C	-20...+40 °C	-20...+40 °C	-20...+40 °C
Humidity	5-90 %	5-90 %	5-90 %	5-90 %
Sound pressure level, average value over time according to ISO 3741, measurement uncertainty according to class 1 measuring instruments for sound level meters.	98 dBA	98 dBA	98 dBA	98 dBA
Vibrations, grinding/polishing	2.43 m/s ²	2.43 m/s ²	2.43 m/s ²	2.43 m/s ²
Permitted daily exposure, grinding/polishing	Unrestricted	Unrestricted	Unrestricted	Unrestricted
Vibrations, Floor preparation (T-Rex)	9.37 m/s ²	9.37 m/s ²	9.37 m/s ²	9.37 m/s ²
Permitted daily exposure, Floor preparation (T-Rex)	2.28 hrs	2.28 hrs	2.28 hrs	2.28 hrs

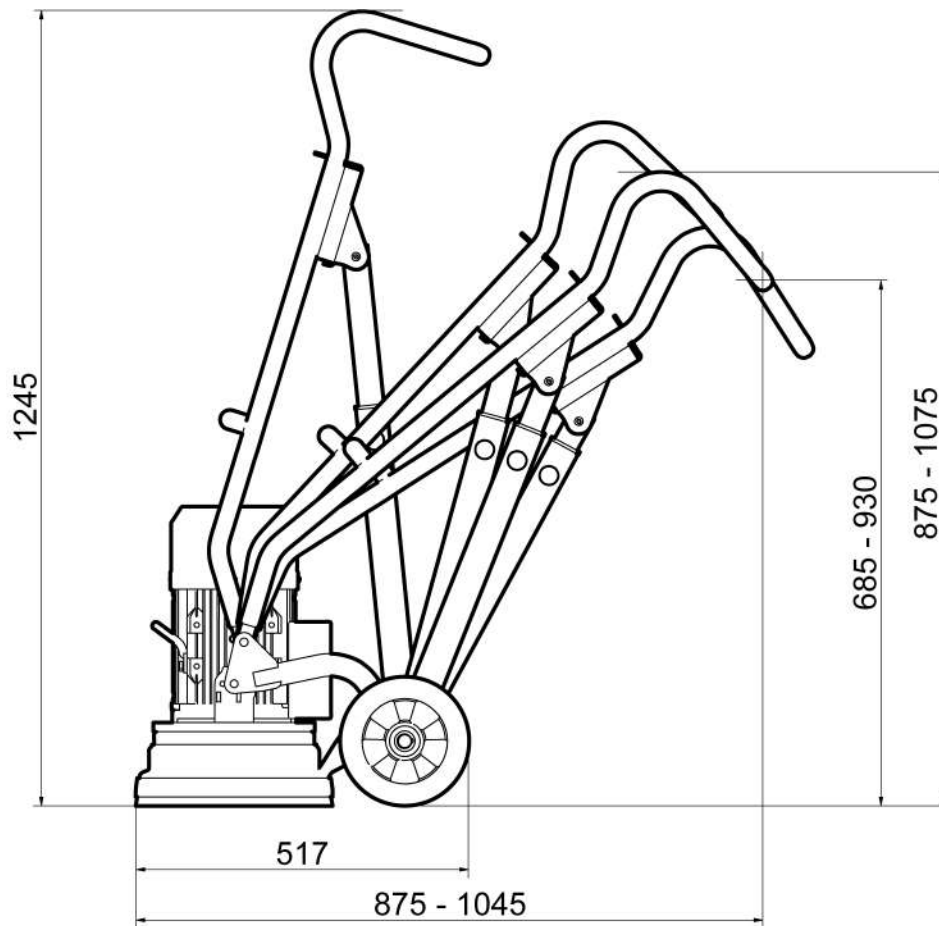

Figure 7-1. Height and length of the machine in millimetres

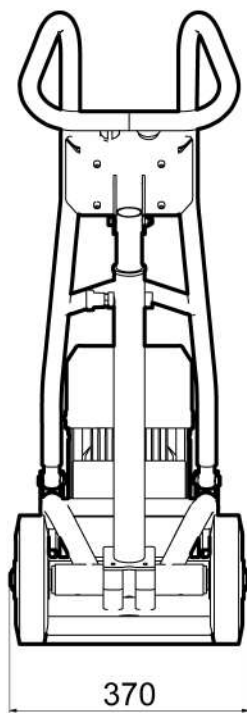

Figure 7-2. Width of the machine in millimetres

7.2 HTC GL 400

	HTC GL 400 3x230V 50Hz EU	HTC GL 400 3x400V EU	HTC GL 400 3x460V US
Part number	113124	113122	113123
Total machine weight	78 kg	78 kg	81 kg
Weight, grinding head	50 kg	50 kg	53 kg
Chassis weight	28 kg	28 kg	28 kg
Grinding pressure	47 kg	47 kg	50 kg
Grinding diameter	400 mm	400 mm	400 mm
Grinding discs	1 x 400 mm	1 x 400 mm	1 x 400 mm
Motor	4 kW	4 kW	3 kW
Tension	3 x 230 V	3 x 400 V	3 x 460 V
Current	14.37 A	8.26 A	5.87 A
Recommended minimum cable area	2.5 mm ²	2.5 mm ²	2.5 mm ²
Frequency	50 Hz	50 Hz	60 Hz
Rotational speed, grinding discs	1430 r.p.m.	1430 r.p.m.	1160 r.p.m.
Storage temperature	-20...+40 °C	-20...+40 °C	-20...+40 °C
Working temperature	-20...+40 °C	-20...+40 °C	-20...+40 °C
Humidity	5-90 %	5-90 %	5-90 %
Sound pressure level, average value over time according to ISO 3741, measurement uncertainty according to class 1 measuring instruments for sound level meters.	100 dBA	100 dBA	100 dBA
Vibrations, grinding/polishing	2.77 m/s ²	2.77 m/s ²	2.77 m/s ²
Permitted daily exposure, grinding/polishing	Unrestricted	Unrestricted	Unrestricted
Vibrations, Floor preparation (T-Rex)	4.83 m/s ²	4.83 m/s ²	4.83 m/s ²
Permitted daily exposure, Floor preparation (T-Rex)	8.56 hrs	8.56 hrs	8.56 hrs

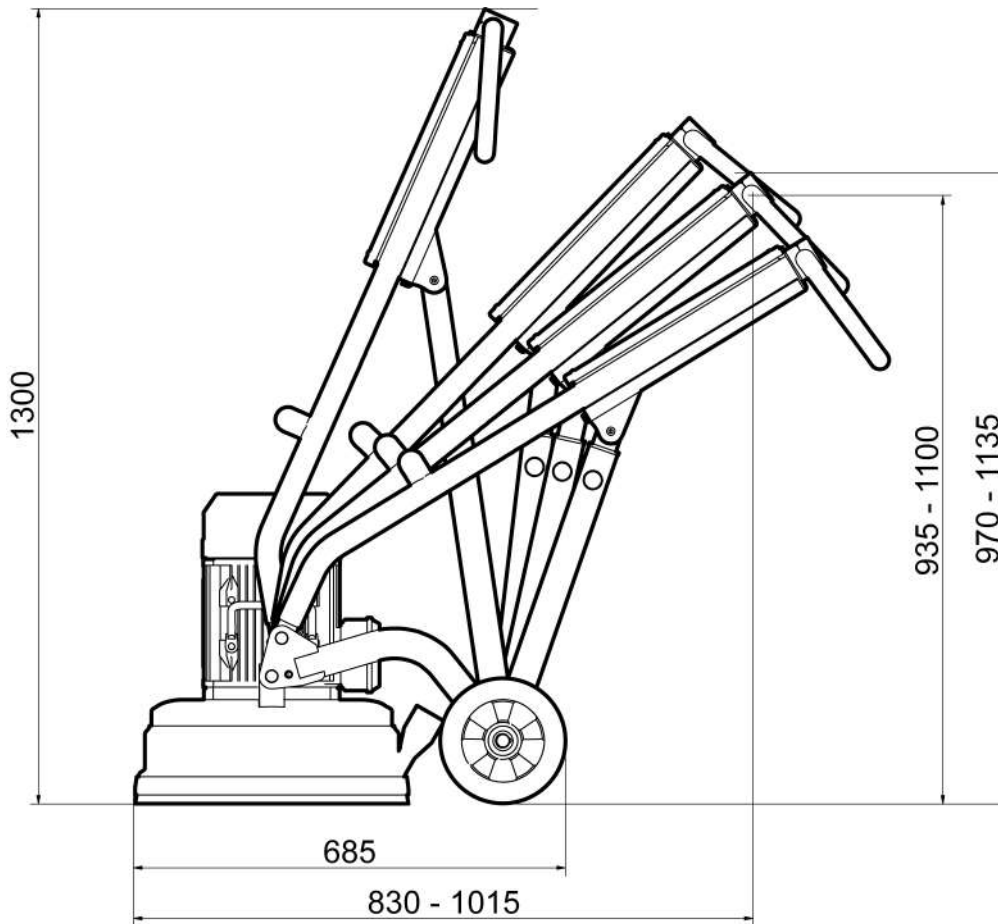

Figure 7-3. Height and length of the machine in millimetres

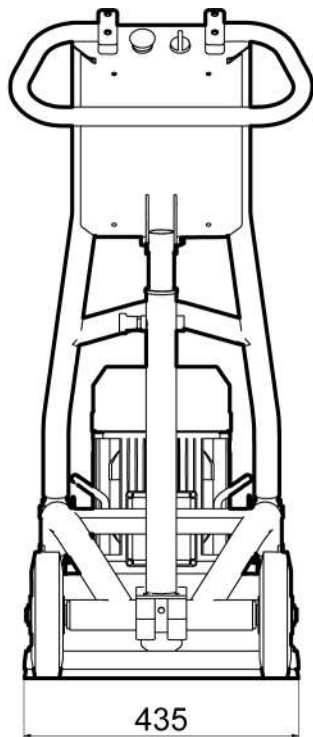

Figure 7-4. Width of the machine in millimetres

7.3 HTC GL 450

	HTC GL 450 110V 50Hz GB	HTC GL 450 110V 60Hz US	HTC GL 450 230V 50Hz EU	HTC GL 450 230V 60Hz US
Part number	113127	113155	113126	113144
Total machine weight	95 kg	95 kg	95 kg	95 kg
Weight, grinding head	68 kg	68 kg	68 kg	68 kg
Chassis weight	27 kg	27 kg	27 kg	27 kg
Grinding pressure	63 kg	63 kg	63 kg	63 kg
Grinding diameter	450 mm	450 mm	450 mm	450 mm
Grinding discs	3 x 180 mm	3 x 180 mm	3 x 180 mm	3 x 180 mm
Motor	1.5 kW	1.5 kW	1.5 kW	1.5 kW
Tension	1 x 110 V	1 x 110 V	1 x 230 V	1 x 230 V
Current	17.58 A	17.58 A	8.31 A	8.31 A
Recommended minimum cable area	2.5 mm ²	2.5 mm ²	1.5 mm ²	1.5 mm ²
Frequency	50 Hz	60 Hz	50 Hz	60 Hz
Rotational speed, grinding discs	480 r.p.m.	576 r.p.m.	480 r.p.m.	576 r.p.m.
Storage temperature	-20...+40 °C	-20...+40 °C	-20...+40 °C	-20...+40 °C
Working temperature	-20...+40 °C	-20...+40 °C	-20...+40 °C	-20...+40 °C
Humidity	5-90 %	5-90 %	5-90 %	5-90 %
Sound pressure level, average value over time according to ISO 3741, measurement uncertainty according to class 1 measuring instruments for sound level meters.	95 dBA	95 dBA	95 dBA	95 dBA
Vibrations, grinding/polishing	1.16 m/s ²	1.16 m/s ²	1.16 m/s ²	1.16 m/s ²
Permitted daily exposure, grinding/polishing	Unrestricted	Unrestricted	Unrestricted	Unrestricted
Vibrations, Floor preparation (T-Rex)	2.35 m/s ²	2.35 m/s ²	2.35 m/s ²	2.35 m/s ²
Permitted daily exposure, Floor preparation (T-Rex)	Unrestricted	Unrestricted	Unrestricted	Unrestricted

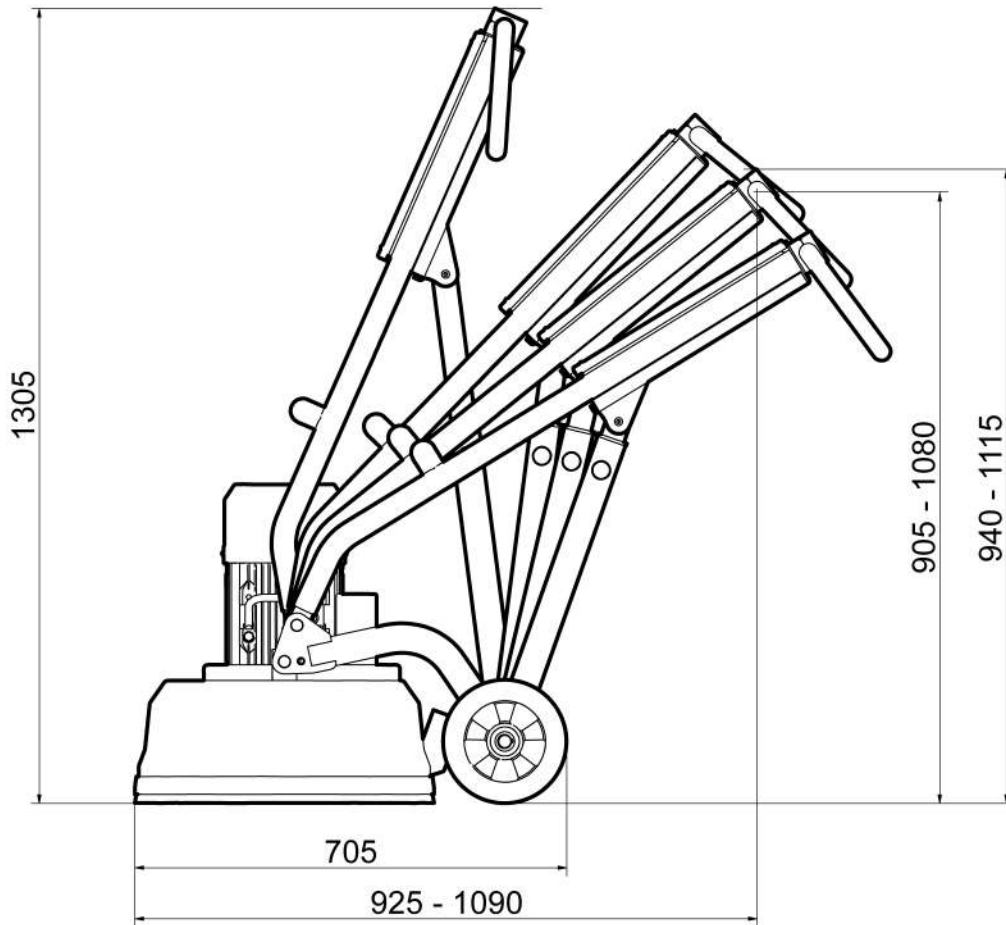

Figure 7-5. Height and length of the machine in millimetres

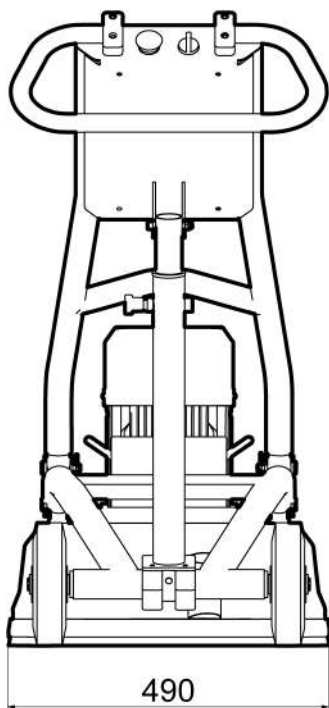

Figure 7-6. Width of the machine in millimetres

7.4 HTC GL 550

	HTC GL 550 3x230V 50Hz EU	HTC GL 550 3x400V EU	HTC GL 550 3x460V US
Part number	113131	113128	113130
Total machine weight	131 kg	131 kg	131 kg
Weight, grinding head	102 kg	102 kg	102 kg
Chassis weight	29 kg	29 kg	29 kg
Grinding pressure	94.7 kg	94.7 kg	94.7 kg
Grinding diameter	530 mm	530 mm	530 mm
Grinding discs	3 x 230 mm	3 x 230 mm	3 x 230 mm
Motor	4 kW	4 kW	4.6 kW
Tension	3 x 230 V	3 x 400 V	3 x 460 V
Current	14.37 A	8.26 A	8.26 A
Recommended minimum cable area	2.5 mm ²	2.5 mm ²	2.5 mm ²
Frequency	50 Hz	50 Hz	60 Hz
Rotational speed, grinding discs	715 r.p.m.	715 r.p.m.	858 r.p.m.
Storage temperature	-10...+40 °C	-10...+40 °C	-10...+40 °C
Working temperature	-10...+40 °C	-10...+40 °C	-10...+40 °C
Humidity	5-90 %	5-90 %	5-90 %
Sound pressure level, average value over time according to ISO 3741, measurement uncertainty according to class 1 measuring instruments for sound level meters.	97 dBA	97 dBA	97 dBA
Vibrations, grinding/polishing	2.50 m/s ²	2.50 m/s ²	2.50 m/s ²
Permitted daily exposure, grinding/polishing	Unrestricted	Unrestricted	Unrestricted
Vibrations, Floor preparation (T-Rex)	3.87 m/s ²	3.87 m/s ²	3.87 m/s ²
Permitted daily exposure, Floor preparation (T-Rex)	13.40 hrs	13.40 hrs	13.40 hrs

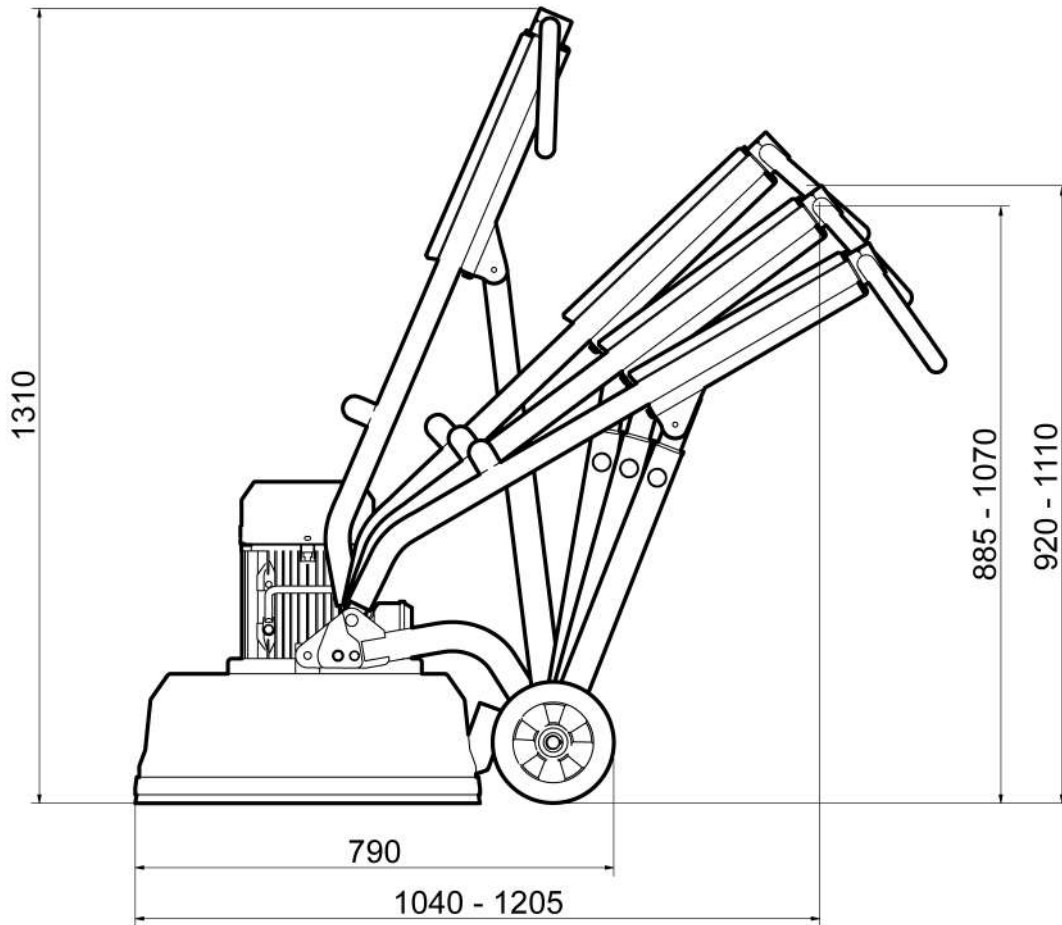

Figure 7-7. Height and length of the machine in millimetres

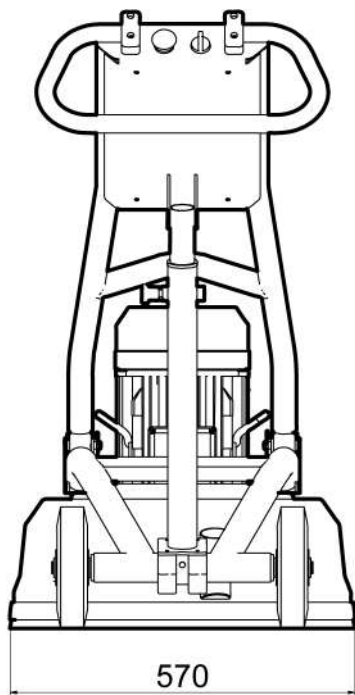

Figure 7-8. Width of the machine in millimetres

8 Environment

HTC's products are constructed mainly of recyclable metal and plastic. The main materials used are listed below.

Chassis	
Frame	Metal, powder-coated
Wheels	Rubber
Fixed parts	Metal
Hose connections	Metal, aluminium
Hoses	Plastic, PUR/PVC

Grinding head	
Lower cover	Metal, aluminium
Cover	Metal, powder-coated
External plate and steel components	Metal, powder-coated
Belts	Rubber and polyamide
Steering grinding cover	Plastic, ABS
Other components	Untreated steel

Electrical system	
Cables	Copper conductors with Neoprene and PVC coating
Motor	Metal, cast iron, aluminium and copper
Enclosure electrical cabinet	Metal, stainless

Plastic components can be recycled by sorting as hard plastics. Electronics can be deposited as electronic waste. Machines or machine components can also be sent back to HTC Sweden AB. For recycling and scrapping of components, see the applicable national regulations for each country.

9 Warranty and CE marking

9.1 Warranty

This warranty only covers manufacturing defects. HTC bears no responsibility for damage that arises or occurs during transportation, unpacking or use. In no instance and under no circumstances shall the manufacturer be held responsible for damage and defects caused by incorrect use, corrosion or use outside the prescribed specifications. The manufacturer is not responsible for indirect damage or costs under any circumstances. For complete information on the manufacturer's warranty period, see HTC's current warranty terms.

Local distributors may have special warranty terms specified in their terms of sale, delivery and warranty. If there is any uncertainty regarding warranty terms, please contact your retailer.

9.2 CE marking

CE marking of a product guarantees its free movement within the EU area in accordance with EU regulations. CE marking also guarantees that the product fulfils various directives (the EMC Directive and other possible requirements in so-called directives for new procedures in accordance with these regulations). This machine carries the CE mark in accordance with the Low Voltage Directive (LVD), the Machinery Directive and the EMC Directive. The EMC Directive states that electrical equipment must not disturb its surroundings with electromagnetic radiation and that it must also be immune to electromagnetic interference in the surroundings.

This machine is classified for use in environments such as heavy industry, light industry and homes. See the Manufacturer's Declaration of Conformity, which shows that the machine is harmonised with the EMC Directive.