

MINNICH

A-1-36 DOWEL DRILL OPERATOR/SERVICE MANUAL



MINNICH MANUFACTURING

1444 ST RT 42
Mansfield, OH 44903

CONTACT

Phone: (419)-903-0010
Email: sales@minnich-mfg.com

REVISION DATE: 11/24/2021

TABLE OF CONTENTS

Chapter 1-Introduction.....	2
General Warnings.....	3
General Safety.....	4
General Specification.....	9
Safety Decal Location.....	11
Drill Steel & Bits.....	13
Chapter 2-Parts Manual.....	15
Usage Calculation.....	15
Set up Operation.....	16
Troubleshooting Air Drill.....	17
Cylinder Service Kits.....	19
Pressure Regulator.....	20
Parts Manual.....	22
Notes.....	29
Warranty.....	30
Parts Ordering Online.....	31

NOTICE

It is Minnich's policy to constantly strive to improve our products. The information, specifications, and illustrations in this publication are based on the information in effect at the same time as approval for printing and publishing. Minnich therefore reserves the right to make changes in design and improvements whenever it is believed the efficiency of the machine which has been shipped or curring any obligation to incorporate such improvements in any machine which has been shipped or is in service. It is recommended that users contact Minnich or a Minnich Dealer for latest revisions.

NOTICE

See engine manual for information pertaining to the engine.

NOTICE

If there are any questions regarding the machine or its application which are not covered in this manual or in other literature accompanying this unit, please contact your Minnich Dealer or Minnich Manufacturing at 419-903-0010 or sales@minnich-mfg.com

⚠ WARNING

CALIFORNIA PROPOSITION 65

Engine exhaust and some of its constituents, and some dust created by power sanding, sawing, grinding, drilling and other construction activities contains chemicals known to the State of California to cause cancer, birth defects and other reproductive harm. Some examples of these chemicals are:

- Lead from lead-based paints.
- Crystalline silica from bricks.
- Arsenic and chromium from chemically treated lumbar.

Your risk from these exposures varies, depending on how often you do this type of work. To reduce your exposure to these chemicals: ALWAYS work in a well ventilated area, and work with improved safety equipment, such as dust masks that are specifically designed to filter out microscopic particles.

⚠ WARNING

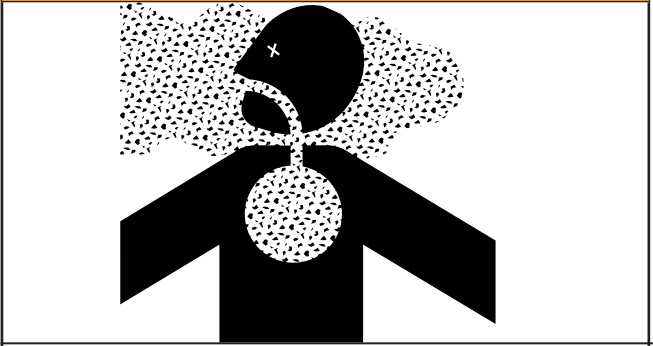

SILICOSIS WARNING

Grinding/cutting/drilling of masonry, concrete, metal and other materials with silica in their composition may give off dust or mist containing crystalline silica.

Silica is a basic components of sand, quarts, brick clay, granite and numerous other minerals and rocks. Repeated and/or substantial inhalation of airborne crystalline silica can cause serious or fatal respiratory disease, including silicosis. In addition, California and some authorities have listed repairable crystalline silica as a substance known to cause cancer. When cutting such materials, always follow the respiratory precautions mentioned above.

⚠ WARNING

RESPIRATORY HAZARDS



Grinding/cutting/drilling of masonry, concrete, metal and fumes containing chemicals known to cause serious or fatal injury or illness, such as respiratory disease, cancer, birth defects or other reproduction harm, if you are unfamiliar with the risks associated with the particular process and/or material being cut or the composition of the tool being used, review the material safety data sheet and/or consult your employer, the material manufacturer/supplier, governmental agencies such as OSHA and NIOSH and other sources on hazardous materials. California and some other authorities, for instance, have published lists of substances known to cause cancer, reproductive toxicity or other harmful effects.

Control dust, mist and fumes at the source where possible. In this regard use good work practices and follow the recommendations of the manufactures of suppliers, OSHA/NIOSH, and occupational and trade associations. Water should be used for dust suppression when wet cutting is feasible. When the hazards from inhalation of dust, mist and fumes cannot be eliminated, the operator and any bystanders should always wear a respirator approved by OSHA/NIOSH for the materials being used.

GENERAL SAFETY

Do not operate or service the equipment before reading the entire manual. Safety precautions should be followed at all times when operating this equipment. Failure to read and understand the safety messages and operating instructions could result in injury to yourself and others.

This operation manual has been developed to provide complete instruction for the safe and efficient operation. Refer to the engine manufactures instructions for data relative to its safe operation. Before using, ensure that the operating individual has read and understood all instructions in the manual. The surrounding environment and you, could be damaged if you do not follow instructions.

SAFETY MESSAGES

The four safety messages shown below will inform you about potential hazards that could injure you or others. The safety messages specifically address the level of exposure to the operator and are preceded by one of four words: DANGER, WARNING, CAUTION or NOTICE.

⚠ DANGER

Indicates a hazardous situation which, if not avoided, WILL result in DEATH or SERIOUS INJURY

⚠ WARNING

Indicates a hazardous situation which, if not avoided, COULD result in DEATH or SERIOUS INJURY

⚠ CAUTION



Indicates a hazardous situation which, if not avoided, COULD result in MINOR or MODERATE INJURY

NOTICE

Addresses practices not related to personal injury

SAFETY SYMBOLS

Potential hazards associated with the operation of this equipment will be referenced with hazards symbols which may appear throughout this manual in conjunction with safety messages.

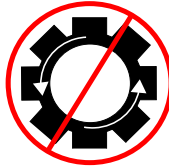
SYMBOL	SAFETY HAZARD
	Respiratory Hazard
	Explosive fuel hazards
	Burn hazard
	Facotory Settings

⚠ WARNING

DO NOT USE TOOL IF IT IS IN NEED OF SERVICE!

GENERAL SAFETY

⚠ CAUTION

△ NEVER operate this equipment without proper protective clothing, shatter proof glasses, respirator protection, hearing protection, steel-toes boots and other protective devices required by the job or city and state regulations.



△ Never operate this equipment when not feeling well due to fatigue, illness or when under medication.



△ NEVER operate this equipment under the influence of drugs or alcohol.



△ ALWAYS check the equipment for loosened threads or bolts before starting.

△ NEVER operate around corrosive chemicals or water containing toxic substances. These fluids could create serious health and environmental hazards. Contact local authorities for assistance.

△ DO NOT use the equipment for any purpose other than its intended purpose or applications.

NOTICE

△ This equipment should only be operated by trained and qualified personnel 18 years of age and older.

△ This equipment is for industrial use only. Whenever necessary, replace nameplate, operation and safety decals when they become difficult to read.

△ Manufacturer does not assume responsibility for any accident due to equipment modifications. Unauthorized equipment modifications will void all warranties. Any modification which it could lead to change in the original characteristics of the machine should be

made only by the manufacturer who shall confirm that the machine is in compliance with appropriate safety regulations.

△ Never use accessories or attachments that are not recommended by Minnich for the equipment. Damage to the equipment and/or injury to user may result.

△ Always know the location of the nearest fire extinguisher.



△ ALWAYS know the location of the nearest first aid kit.



△ ALWAYS know the location of the nearest phone or keep a phone on the job site. Also, know the phone numbers of the nearest ambulance, doctor and fire department. This information will be invaluable in the case of an emergency.



⚠ DANGER

△ NEVER operate the equipment in an explosive atmosphere, near combustible materials, or near flammable or low flash point fluids. An explosion or fire could result causing severe bodily harm or even death.



⚠ WARNING

△ NEVER disconnect any emergency or safety devices. These devices are intended for operator safety. Disconnection of these devices can cause severe injury, bodily harm or even death. Disconnection of any of these will void all warranties.

△ NEVER operate equipment with the covers or guards removed. Keep fingers, hands, hair and clothing away from all moving parts to prevent injury. Wear clothing that will not likely become caught in the equipment or snag on any moving parts.

⚠ CAUTION

△ ALWAYS be sure the operator is familiar with the proper safety precautions and operating techniques before using.

△ NEVER leave the machine unattended.
Turn off when unattended

GENERAL SAFETY

- △ DO NOT expose vibrator to rain.
- △ DO NOT use vibrator motor in damp or wet locations without proper electrical circuits.
- △ DO NOT immerse the motor part in concrete.
- △ ALWAYS keep clear of rotating or moving parts while operating.
- △ NEVER leave the machine unattended while running
- △ ALWAYS disconnect the motor from the power source when not in use, before servicing, and when changing flexible shafting and vibrator heads.

- △ Allow the machine to cool before servicing. Contact with hot components can cause serious burns.



- △ Before Each use, ALWAYS check the motor to make certain that there are no damaged parts and that all parts function properly. If any damage or malfunctioning parts are found, have them repaired or replaced by an authorized service facility.

NOTICE

- △ ALWAYS secure forms. Make sure the form work is well made and braced to withstand the stresses made by vibration.
- △ ALWAYS keep vibrator motor clean for better and safer operation.
- △ ALWAYS store equipment properly when it is not being used. Equipment should be stored in a clean, dry location out of reach of children and unauthorized personnel.
- △ Use only factory authorized replacement parts.
- △ Store idle vibrator motor. When not in use, motor should be stored in a dry, safe storage area.

ENVIRONMENTAL SAFETY/DECOMMISSIONING

NOTICE

- △ DO NOT pour waste or oil directly into the ground, down a drain or into any water source.
- △ Contact you country department of Public Works or recycling agency in your area and arrange for proper disposal of any electrical components, waste or oil associated with this equipment.



- △ When the life cycle of this equipment is over, remove battery (if equip) and bring to appropriate facility for lead reclamation. Use safety precautions when handling batteries that contain sulfuric acid.
- △ When the life cycle of this equipment is over, it is recommended that the unit frame and all other metal parts be sent to a recycling center.

Metal recycling involves the collection of metal from discarded products and its transformation into raw materials to use in many Manufacturing a new product.

Recyclers and manufactures alike promote the process of recycling center promotes energy cost savings.

NOTICE

Decommissioning is a controlled process used to safely retire a piece of equipment that is no longer serviceable. If the equipment poses an unacceptable and unrepairable safety risk due to wear or damage or is no longer cost effective to maintain (beyond life-cycle reliability) and is to be decommissioned (demolition and dismantlement), be sure to follow rules below.

- △ ALWAYS observe all applicable compulsory regulations relevant to environmental protection, especially fuel storage, the handling of hazardous substances, and the wearing of protective clothing and equipment. Instruct the user as a necessary, or, as the user, request this information and training.

GENERAL SAFETY

- △ ALWAYS Dispose of hazardous waste properly. Examples of potentially hazardous waste include used motor oil, fuel, and fuel filters.
- △ DO NOT use food or plastic containers to dispose hazardous waste.
- △ DO NOT pour waste or oil directly onto the ground, down or drain or into any waste source.

NOTICE

- △ ALWAYS keep the machine in proper running condition.
- △ ALWAYS become familiar with the components of the machine before operation.
- △ Fix damage to machine and replace any broken parts immediately.
- △ ALWAYS store equipment properly when it is not being used. Equipment should be stored in a clean, dry location out of the reach of children and unauthorized personnel.
- △ NEVER lubricate components or attempt service on a running machine

CAUTION

- △ NEVER tamper with the factory settings of the engine or engine governor. Damage to the engine or equipment can result in operation in speed ranges above the maximum allowability.

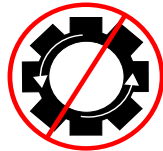

BEFORE CONNECTING THE AIR COMPRESSOR:

CAUTION

- △ Install the drill steel and bits into the drill motors and close the latch retainers and rod guides.
- △ Make sure that the air compressor is set at an operating pressure of not more than 120 PSIG (8Bar)
- △ Make sure air line is cleaned out and is of the proper size and pressure rating for the drill unit.
- △ Make sure the lubricator is filled with proper lubricant. See Minnich recommended lubricant below.

- △ Make sure all controls are in the “off” position and the lift lever (if so equipped) is in the “up” position.
- △ Make sure all lock pins are in their locked position.

WARNING

- △ NEVER attempt to loosen any compressed air hose that is pressurized.
- △ KEEP AWAY from all hot or spark generating objects, do not smoke when handling fuel.
- △ So as to facilitate shipment, new or repaired units are not lubricated before delivery to customers.
- △ DO NOT use hydrocarbons and especially do not use fuel oil for lubricating purposes.
- △ DO NOT OPERATE MACHINE WITHOUT GUARDS AND COVERS IN PLACE
- △ ALWAYS disconnect the air supply before changing steel or dismantling the tool for service or repair. For maximum safety we advise the installation of a shut-off valve at the end of the air line.
- △ NEVER operate the engine with heat shields or guards removed.
- △ DO NOT remove the engine oil drain plug while the engine is hot. Hot oil will gush out of the engine crankcase and severely scald any persons in the general area of the machine.



NOTICE

- Δ CLEAR AIR SUPPLY LINE: Before connecting vibrator, clear the compressed air supply line of possible impurities, contaminants and water.
- Δ LUBRICATE: Every day or every four hours of continuous service, pour a ½ teaspoon of non-detergent oil into the quick release coupling. NOTE: An optional oiler/strainer is available.

CONNECT/START

NOTICE

If the vibration intensity drops, check that the filters are not clogged or that hoses are not kinked.

STORAGE

NOTICE

To properly store unit after use, hang the vibrator with the head up and set the handle (variable control assembly) in the open position to permit the discharge of possible impurities, contaminants and water.

PLACEMENT AND CONSOLIDATION

NOTICE

The force exerted by an internal concrete vibrator is controlled by the weight and the speed at which the eccentric rotates. The centrifugal force exerted can be arrived at by various combinations of weight (size of eccentric weight) and the speed at which the weight rotates. For years the most favorable working speed for a vibrator was considered to be around 10,200 RPM (VPM) and consequently this figure is used in many vibrator comparisons. More recently, the optimum speed for compaction has been accepted as being between 7500 and 9000 RPM.

PERSONAL SAFETY

- Δ Stay alert, watch what you are doing, and use common sense when operating the machine.
- Δ DO NOT use the tool while tired or under the influence of drugs, alcohol, or medication. A moment of inattention while operating power tools may result in serious personal injury or death.
- Δ Dress properly. DO NOT wear loose clothing or jewelry. Tie up long hair. Keep your hair, clothing and gloves away from moving parts. Loose clothes, jewelery, or long hair can be caught in moving parts.
- Δ DO NOT overreach. Keep proper footing and balance at all times. Proper footing and balance enables better control in unexpected situations.

SERVICE

- Δ weplacement parts. Use of unauthorized parts may create a risk of injury or death.

NOTICE

To find the latest revision of this publication, visit our website at: www.minnich-mfg.com

NOTICE

THIS MANUAL MUST ACCOMPANY THE EQUIPMENT AT ALL TIMES.

NOTICE

Specifications and part numbers are subject to change without notice.

A-1-36 SPECIFICATIONS

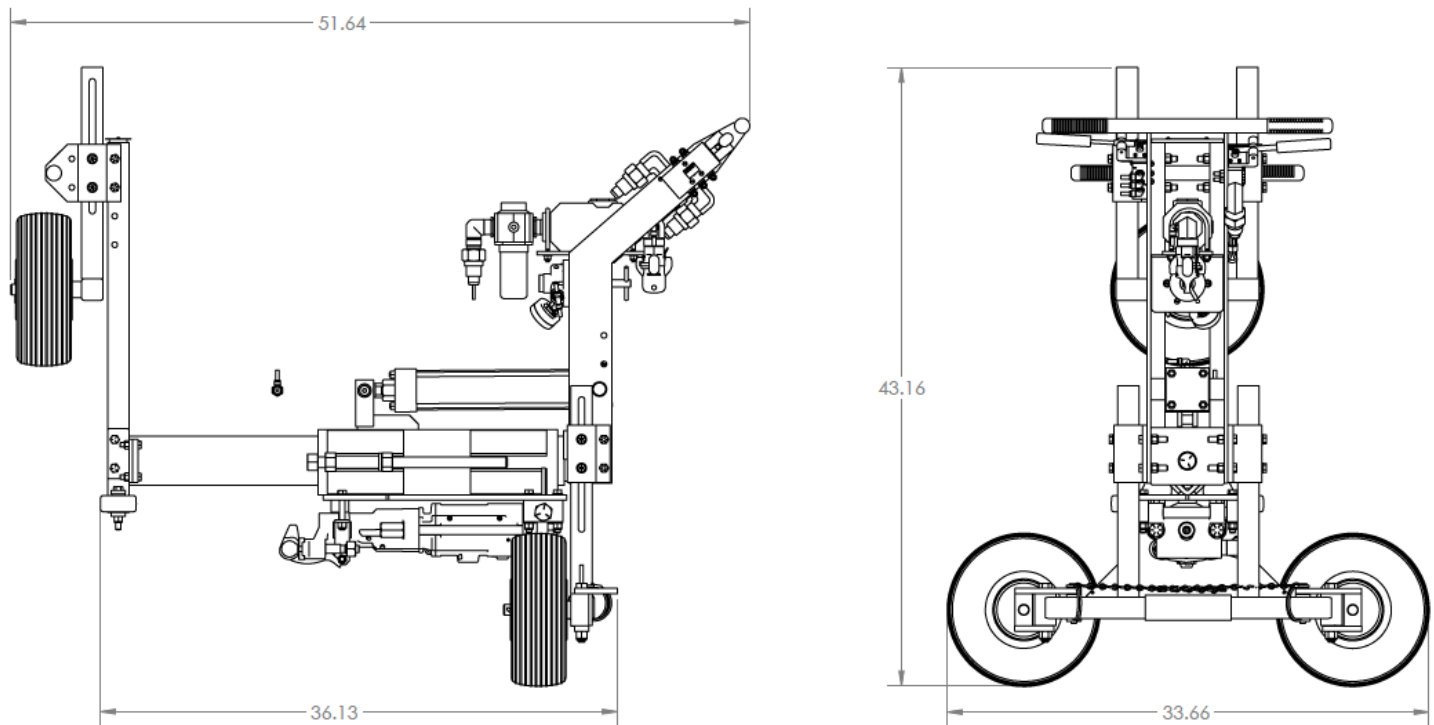

THE A-1 CAN BE CONFIGURED FOUR DIFFERENT WAYS. THERE IS NO NEED TO PURCHASE EXTRA CONVERSION KITS.

1. Two wheel on grade for more accurate drilling
2. One wheel on grade for drilling 6" (15.2cm) to corner
3. Wall configuration for zero clearance drilling
4. Vertical configuration for all vertical applications

MODEL

A-1-36

Drill Steel Shank	.875" x 4.25" (22.2mm x 107.9mm)
Drill Steel Length U.C.	12"(30.5cm)
Drill Bit Diameter	.625" – 2.50" (15.9mm to 63.5mm)
*Maximum Drill Depth	10" (25.4cm)
Drill Distance From Top of Slab	3" - 12" (7.6cm to 30.5cm)
Minimum Cutout Width	36" (91.4cm)
SCFM Required	92.2 (2.61 m3/min)
PSIG Required	90 (6.2 BAR)
Weight	185lbs. (83.9kg)

GENERAL SPECIFICATION

PNEUMATIC CONNECTION:

- Approved air disconnect is required to be installed in accordance to Local & National Codes.

ENVIRONMENTAL:

- +5°C to +40°C (+41°F to +104°F)
- 50% Rh at +40°C (+104°F), (90% Rh at +20°C (+68°F))
- Altitude – 1000m (3280ft) above mean sea level
- Unit is to be disposed according to all Local and National Regulations

TRANSPORTATION AND STORAGE:

- -25°C to +55°C for 24 hours (-13°F to +131°F)

INGRESS PROTECTION:

- Protection level IP2X is provided

SOUND:

- System operates at sound levels about 85dBA and 85dBC. Hearing protection is required.

PNEUMATIC HAMMER:

- DO NOT force tool. Use the correct toll for your application.
- DO NOT use the machine if valve handles do not turn drill on/off.
- DO NOT make any adjustment while air is hooked up to the machine.

OPERATION OF MACHINE:

- DO NOT overreach, keep proper footing and balance at all times.
- DO NOT wear loose clothing, or jewelry. Tie up long hair.
- DO NOT use the machine if maintenace is required.

TRANSPORTATION, SERVICE AND STORAGE:

- DO NOT use your hands to search for air leaks
- DO NOT service the machine unless you are qualified
- KEEP OIL reservior filled - run drill frequently to keep the system lubricated.

THE A-1 CAN BE CONFIGURED FOUR DIFFERENT WAYS.

THERE IS NO NEED TO PURCHASE EXTRA CONVERSION KITS.

1. Two wheel on grade for more accurate drilling
2. One wheel on grade for drilling 6" (15.2cm) to corner
3. Wall configuration for zero clearance drilling
4. Vertical configuration for all vertical applications

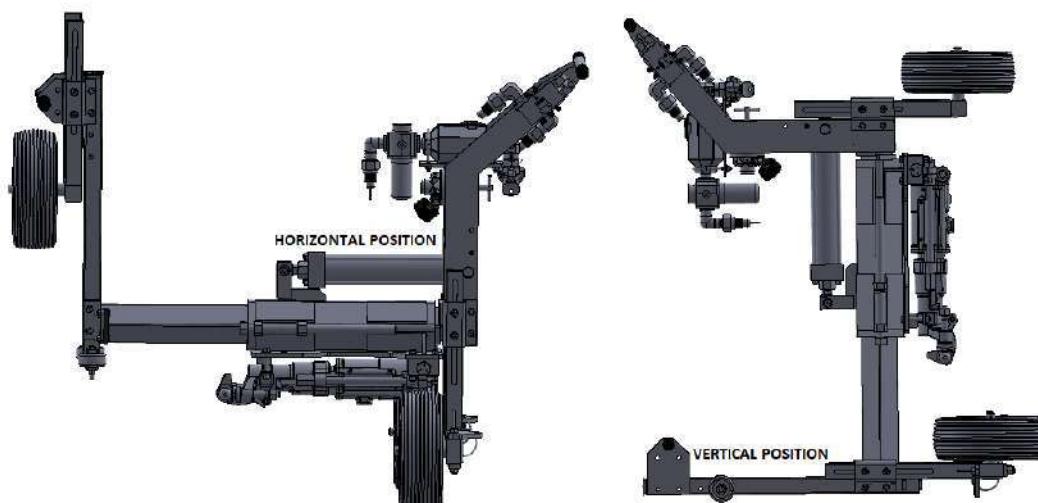

NOTICE

All safety labels on Minnich Manufacturing units have been carefully placed so they can be easily seen at all times. There are several different types of labels on the units. Always keep these warnings free of dirt, concrete, or anything else that restricts visibility. Never remove the labels for any reason. If the label on your machine become worn or in any way difficult to read, call our parts department for replacements.



- F**
- PRIOR TO OPERATION**
- READ & UNDERSTAND OWNERS MANUAL COMPLETELY.
 - TIGHTEN ALL LOOSE BOLTS INSPECT ALL LINES, PIPES, AND HOSES FOR DAMAGE. REPAIR AS NECESSARY.
 - DRILL STEEL MUST NOT BE BINDING IN GUIDE BEARING. MAKE SURE DRILL STEEL IS STRAIGHT, FREE OF OBSTRUCTIONS, AND NOT BINDING IN ANYWAY.
 - FILL THE OILER-PER MANUAL.
- 12287-43

G

WARNING	
	NOISE MAY DAMAGE HEARING WEAR PROPER HEARING PROTECTION
	FLYING PARTICLES MAY CAUSE EYE INJURIES WEAR PROPER EYE PROTECTION
	DUST CAN CAUSE INJURY TO YOUR HEALTH IF VENTILATION IS INADEQUATE USE AN APPROVED RESPIRATOR
	HIGH PRESSURE KEEP AWAY FROM LEAKS BLEED DOWN BEFORE REMOVING LINES TO SERVICE

12287-3



I **Feed Pressure**
Recommended Setting
16 - 22 PSI

J **Drill**

K **Feed**

L

ATTENTION

FILL OIL RESERVOIR EVERY TWO HOURS

M **7/8" HEX x 3 1/4"**

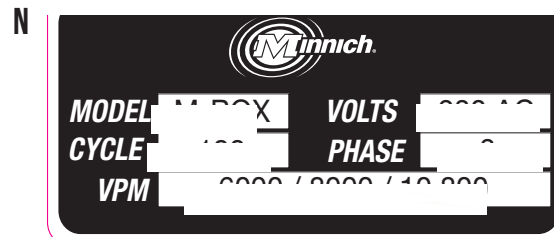

SAFETY DECAL LOCATION

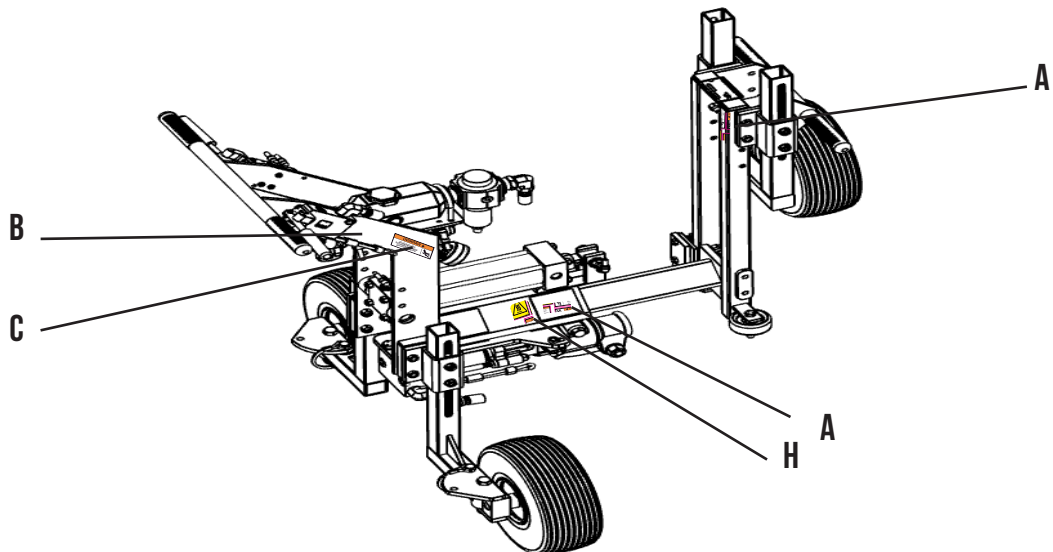
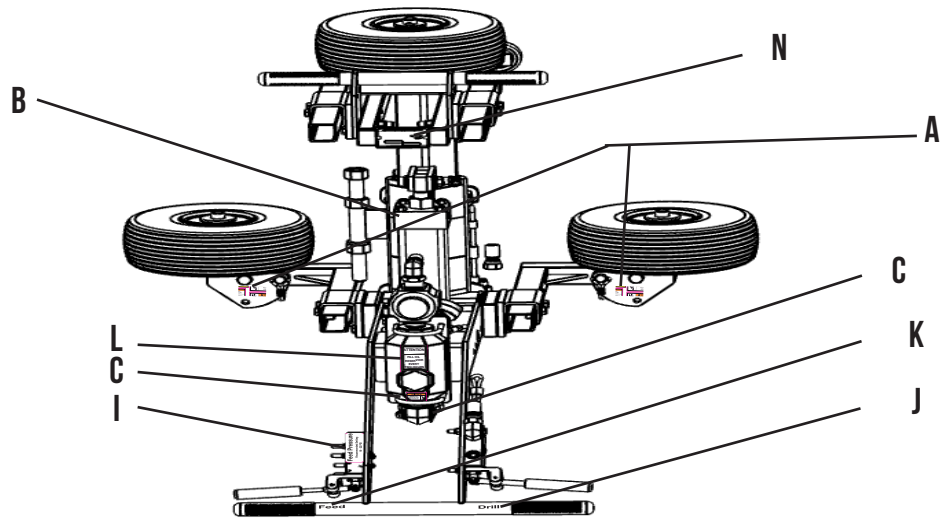
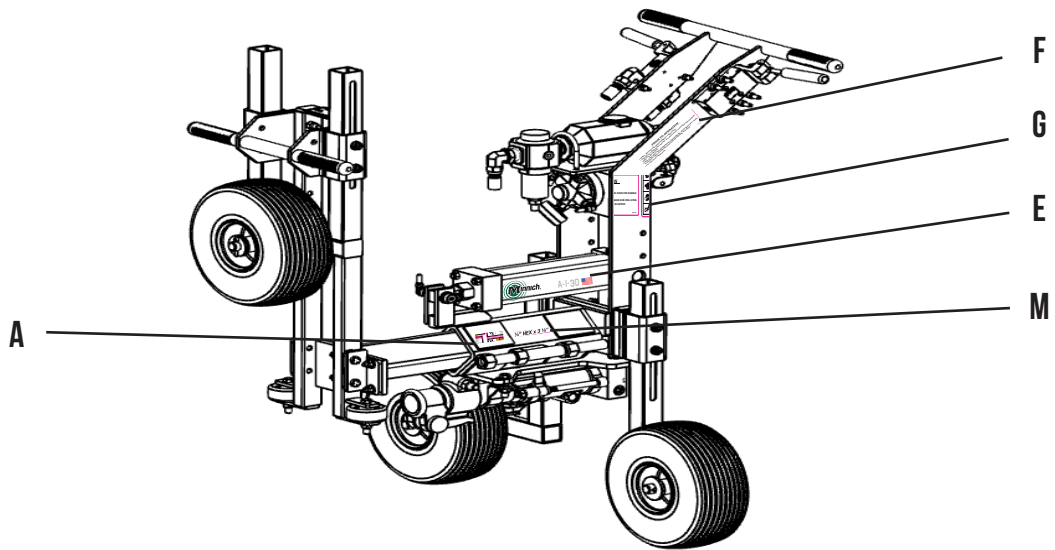

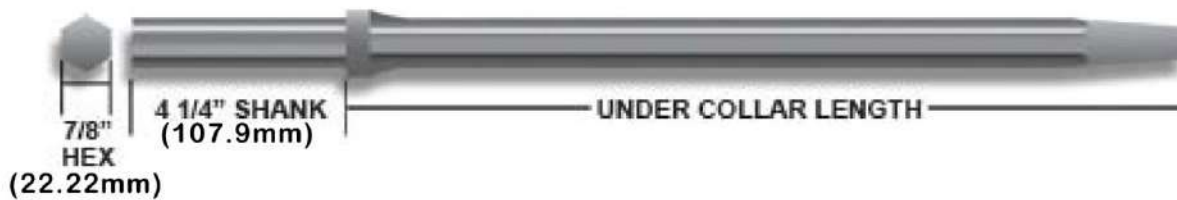
HOW TO MEASURE STEEL FOR ORDER**WARRANTY POLICY**

All drill steel and bits sold to customer are intended for use in drilling concrete. It is not capable of drilling through steel mesh, rebar or dowel bars. Use in these applications will void all warranties and dramatically shorten bit life. Bit life is also affected by the sharpness of the bit, type of aggregate and condition of concrete. Minnich Manufacturing's drill steel and bit warranty is limited to the warranty provided by the supplier. All warranty claims must be submitted to Minnich for evaluation and sent to the supplier for authorization.

GENERAL NOTES

1. 2" (50.8mm) diameter maximum bit for hydraulic drills.
2. 2 1/2" (63.5mm) diameter maximum bit for pneumatic drills.
3. 5/8" (16mm) diameter is the smallest hole diameter.
4. Cutting speed varies from 15 to 30 seconds for a 6" (152.4mm) deep hole, depending on bit diameter and aggregate.
5. On average you can get 180 holes, 9" (228.6mm) deep per bit.
6. On average you can get 600 holes, 9" (228.6mm) deep per drill steel.
7. Removable bits are carbide and cannot be re-sharpened.
8. Whirly bit steel can be re-sharpened twice.

DRILL STEEL & BITS OPTIONS

1 PIECE STEEL & BIT (WHIRLY BIT)

PART NUMBER	HOLE DIAMETER	SHANK SIZE	UC LENGTH
005367-12.00	5/8" (15.9mm)	7/8" x 4 1/4" (22.2mm x 107.9mm)	12" (30.5cm)
005367-24.00	5/8" (15.9mm)	7/8" x 4 1/4" (22.2mm x 107.9mm)	24" (61.0cm)
004209-12.00	3/4" (19.1mm)	7/8" x 4 1/4" (22.2mm x 107.9mm)	12" (30.5cm)
004209-24.00	3/4" (19.1mm)	7/8" x 4 1/4" (22.2mm x 107.9mm)	24" (61.0cm)
004541-12.00	7/8" (22.2mm)	7/8" x 4 1/4" (22.2mm x 107.9mm)	12" (30.5cm)
004541-24.00	7/8" (22.2mm)	7/8" x 4 1/4" (22.2mm x 107.9mm)	24" (61.0cm)
004745-12.00	1" (25.4mm)	7/8" x 4 1/4" (22.2mm x 107.9mm)	12" (30.5cm)
004745-24.00	1" (25.4mm)	7/8" x 4 1/4" (22.2mm x 107.9mm)	24" (61.0cm)

ALL 4 1/4" (107.9MM) SHANKS CAN BE CUT TO A 3 1/4" (82.55MM) SHANKS

TAPERED STEEL

PART NUMBER	SHANK SIZE	UC LENGTH	NOTES
003749-12.00	7/8" x 4 1/4" (22.2mm x 107.9mm)	12" (30.5cm)	For 1" (2.54cm) Bits ONLY 003747-1.000
003749-24.00	7/8" x 4 1/4" (22.2mm x 107.9mm)	24" (61.0cm)	
004116-12.00	7/8" x 4 1/4" (22.2mm x 107.9mm)	12" (30.5cm)	For 1 1/8" (2.86cm) & Larger Bits ONLY
004116-24.00	7/8" x 4 1/4" (22.2mm x 107.9mm)	24" (61.0cm)	

TAPERED BITS

PART NUMBER	SHANK SIZE	UC LENGTH	NOTES
003747-1.000	1" (2.54cm)	003839-00000	Use 003749-12.00 or 003749-24.00 Steel ONLY
003747-1.120	1 1/8" (2.86cm)	003901-00000	
003747-1.180	1 3/16" (3.01cm)	003901-00000	
003747-1.250	1 1/4" (3.18cm)	003901-00000	
003747-1.310	1 5/16" (3.34cm)	003901-00000	
003747-1.370	1 3/8" (3.49cm)	003901-00000	
003747-1.430	1 7/16" (3.65cm)	003901-00000	
003747-1.500	1 1/2" (3.81cm)	003901-00000	Use 004116-12.00 or 004116-24.00 Steel ONLY
003747-1.560	1 9/16" (3.97cm)	003901-00000	
003747-1.620	1 5/8" (4.13cm)	003901-00000	
003747-1.750	1 3/4" (4.45cm)	003901-00000	
003747-1.810	1 13/16" (4.60cm)	003901-00000	
003747-1.880	1 7/8" (4.76cm)	003901-00000	
003747-2.000	2" (5.08cm)	003901-00000	

ALL 4 1/4" (107.9MM) SHANKS CAN BE CUT TO A 3 1/4" (82.55MM) SHANKS

"H" THREAD STEEL

PART NUMBER	SHANK SIZE	UC LENGTH
005061-24.00	7/8" x 4 1/4" (22.2mm x 107.9mm)	24" (61.0cm)
05061B-24.00	1" x 4 1/4" (25.4mm x 107.9mm)	24" (61.0cm)

"H" THREAD BITS

PART NUMBER	HOLE DIAMETER	NOTES
005140-1.370	1 3/8" (3.49cm)	
005140-1.500	1 1/2" (3.81cm)	
005140-1.620	1 5/8" (4.13cm)	
005140-1.750	1 3/4" (4.45cm)	
005140-1.870	1 7/8" (4.76cm)	
005140-2.000	2" (5.08cm)	
005140-2.250	2 1/4" (5.72cm)	
005140-2.500	2 1/2" (6.35cm)	Multiple use bit

ALL 4 1/4" (107.9MM) SHANKS CAN BE CUT TO 3 1/4" (82.55MM) SHANKS

USAGE CALCULATION

USAGE CALCULATION

The calculations below are nominal and could vary depending on the hardness of the concrete, aggregates used and the possibility of bits hitting steel reinforcement.

Whirly Bit, Taper Bit and "H" Thread Bit

(B)Bit=180 holes x 9" (22.86cm)

B=1620" (4114.8cm)

Number of bits needed = (number of holes x hole depth)/1620"

Taper Steel and "H" Thread Steel

(S)Steel=600 holes x 9" (22.86cm)

S=5400" (13716cm)

Number of steels needed = (number of holes x hole depth)/5400"

Example:

Need 50,000 Holes 12" (30.48cm) Deep for the job.

$(50,000 \times 12) / 1620 = 371$ Bits

$(50,000 \times 12) / 5400 = 112$ Steels

DRILL BIT INSTALLATION

1. Check to see that the hole through the center of the drill steel is not blocked, if so remove the object.
2. Clean the tapered end of the drill steel and the inside of the drill bit with a non-oily cleaner, making sure not to leave any oily residue.
3. Make sure a brass shim is in the drill bit. If not, carefully roll a new one and slide it into the bit making sure that the ends do not overlap.
4. Put the drill bit on the tapered end of the drill steel and tap it on a firm surface to seat the bit.

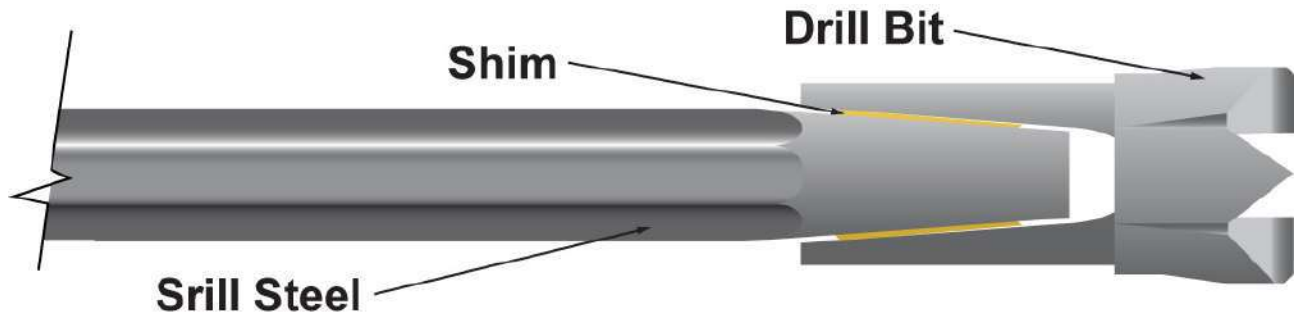

DRILL BIT REMOVAL

1. Swing latch so that drill steel can be removed from drill.
2. Pull drill steel out of drill.
3. Using two hammers, place one hammer on bottom side of bit. Using other hammer, strike the bit on the topside. Rotate drill steel 1/4 turn and strike top of bit again. Repeat procedure until bit comes off.

⚠ CAUTION

Bit may pop off of drill steel with some force.

- STEP 1** Be sure lubricator is full. See recommended oils below.
- STEP 2** Make sure slab wheels are square against face of slab.
- STEP 3** Using feed control valve, feed bit against slab.
- STEP 4** Using drill control valve, turn drill on and drill until the drill slider is against the stop clamp, which should be set for the required depth of hole.
- STEP 5** Once drill slider is against the stop clamp, leave the drill on and use the feed control valve to retract the drill from the hole. Note: If bit will not retract from hole, feed drill back into hole and retract drill again.

NOTICE

DO NOT hit drill slider to retract the bit from the hole. This will damage the drill slider.

AMBIENT TEMPERATURE (EQUIVALENT SAE)

SUPPLIER	BELOW 4°C (SAE 10W)	4°C-36°C (SAE 202, 30)	ABOVE 36°C (SAE 40)
AGIP		Rock Drill RD100	
Caltex	RPM Vistac Oil 32X or Rock Drill Lube 46	RPM Vistac Oil 100X	RPM Vistac Oil 230X
Texaco	Rock Drill Lube 46	Rock Drill Lube 100	Rock Drill Lube 320
Chevron	Vistac Oil 32X	Vistac Oil 100X	Vistac Oil 320X
Mobil	Almo Oil No. 1	Almo Oil No. 2	Almo No. 5
Shell		Shell Tona Oil R100	Shell Tona Oil R320 (140)

DO NOT USE ENGINE OIL, DIESEL OR HYDRAULIC FLUID

PROBLEM: DRILL DOES NOT RUN

CAUSE

REMEDY

DRILL NOT GETTING AIR

1. On Multi Drill units, switch airline with drill that is working properly. If drill now runs check the air control valve. If the valve works, check the drill.
2. Check clave on air compressor and drill unit to be certain they are completely open
3. Check compressor. It should have 100SCFM (47.20m³/sec.) per drill and 110PSI (7.6 BAR) at drill manifold when drilling with large drills.
4. Make certain all fittings are connected properly and not leaking.

COUPLING OR HOSE OBSTRUCTION Remove Obstruction

FAILURE IN THE ELECTRICAL CIRCUIT

Check switches, connections, coils, ground & voltage. If the power unit (backhoes, grader, ETC.) is being jump started, check the AMPS & voltage being jump supplied to coils from the battery, it may be too low.

FAILURE OF DRILL SOLENOID VALVE (MULTI DRILL UNITS WITH REMOTE ELECTRICAL CONTROLS)

Check valve - you should be able to feel the solenoid move when it is actuated. Make sure you have current to the solenoid coil. Replace the solenoid if there is no movement.

MECHANICAL FAILURE OF DRILL

Disassemble the drill & inspect for damaged parts.

TROUBLE SHOOTING AIR DRILL

PROBLEM: DRILL RUNS SLOW OR DOES NOT DRILL EFFECTIVELY

CAUSE	REMEDY
NOT ENOUGH AIR REACHING DRILL. IT SHOULD HAVE 100SCFM (47.2DM ³ /SEC.) PER DRILL AND 110 PSI (7.6 BAR)	On Multi Drill units. Turn off one or two drills. If the remaining drills pick up speed, check the air compressor.
RESTRICTION IN AIR LINE	A foreign object in the air line or possibly a reduction in the air line caused by a reducer fitting.
TOO SMALL AIR LINE	Following are supply line sizes for drilling: A-1 Single Drill 3/4" (19mm) A-2 Two Drills 1-1/4" (38.75mm) A-3& A-4 Three & four drills 1-1/2" (38.1mm) A-5 Five Drills 2" (50.8mm)
AIR PRESSURE TO CYLINDER "FEEDING" DRILL INTO CONCRETE NOT ADJUSTED PROPERLY	Excessive pressure can cause drill to "bind up" in the hole. Pressure that is too low will not "feed" the drill into the concrete. The air pressure required varies with the drill model. Horizontal- all units with large drills use 22-26 PSI (1.5-1.8 bar). Drill units using the 15LB (6.8kg) class drill will use 16-20 PSI (1.1-1.4 Bar). Vertical - all drill units use 5-6 PSI (0.34-0.41 Bar). With the correct air pressure, the drill steel should have a slight rattle.
INSUFFICIENT AIR FLOW TO KEEP HOLE BLOWN CLEAN	Check for obstruction in the blow tube in the drill.
LUBRICATOR PUTTING OUT TOO MUCH OIL TO DRILL	If you notice more than a light film of oil on the air deflector on the bottom of the drill adjust the lubricator, make certain you are using the type of oil called for in the operation and maintenance manual.
MECHANICAL BLINDING OF DRILL CARRIER	Make sure the eight bearing pads are adjusted correctly. The square tube that the drill carrier slides on must be free of rust so that the carrier slides freely, drill steel must not be binding in the guide bearing.
BENT DRILL STEEL, WORN DRILL BIT OR DRILLING INTO REBAR	Replace the drill steel or bit. If drilling into rebar, move the drill.
USING 3 1/4" (8.25CM) SHANK DRILL STEEL IN 4 1/4" (10.8CM) SHANK CHUCK DRILL	The drill steel will rotate but it will not allow the drill piston to hammer properly, replace it with the correct 4 1/4" (10.8cm) drill steel.

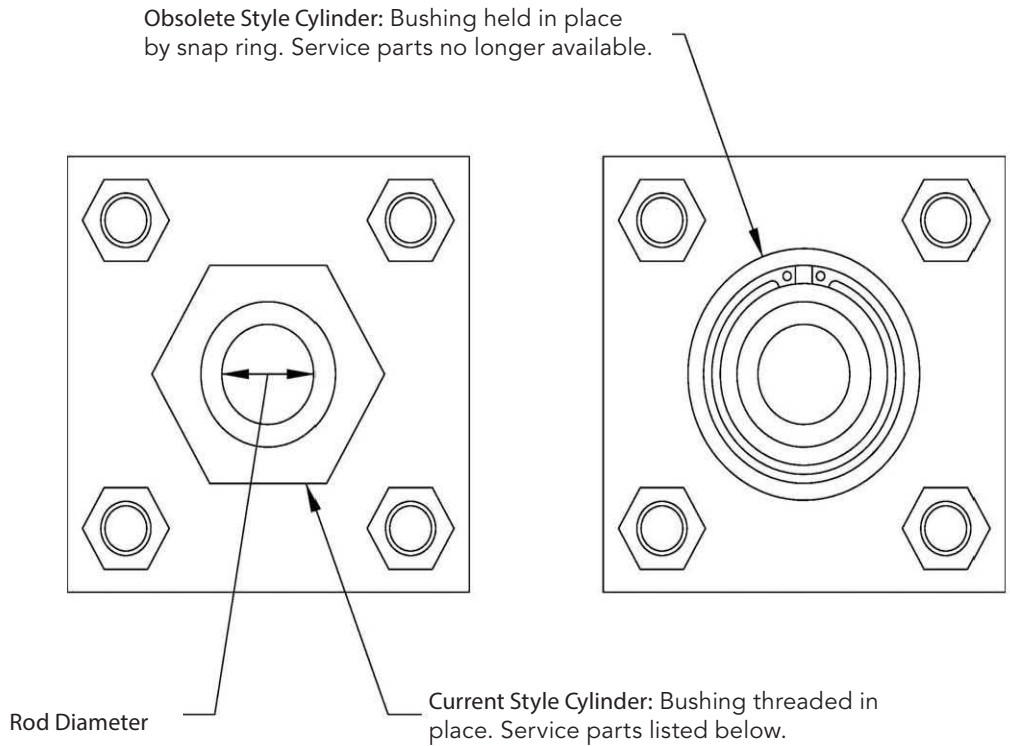

OVERSIZE ROD CYLINDERS (FEED)

STANDARD ROD CYLINDERS

	ROD DIAMETER	SERVICE KIT PART #	ROD DIAMETER	SERVICE KIT PART #
1.50" (3.81 cm) Bore			5/8" (1.59 cm)	A12899-1.500
2.50" (6.35 cm) Bore	1" (2.54 cm)	A12895-2.500	5/8" (1.59 cm)	A12899-2.500
3.25" (8.26 cm) Bore	1 3/8" (3.49 cm)	A12895.3.250	1" (2.54 cm)	A12899-3.250
4.00" (10.16 cm) Bore			1" (2.54 cm)	A12899-4.000
5.00" (12.70 cm) Bore			1" (2.54 cm)	A12899-5.000
6.00" (15.24 cm) Bore			1 3/8" (3.49 cm)	A12899-6.000
7.00" (17.78 cm) Bore			1 3/8" (3.49 cm)	A12899-7.000

PRESSURE REGULATOR

MINNICH P/N 002880-00000

OPERATION

A regulator is used in a compressed air system to maintain nearly constant outlet pressure despite changes in the inlet air pressure and changes in downstream flow requirements. Outlet pressure is controlled by the adjusting screw (1). clockwise rotation increases and counter-clockwise rotation decreases outlet pressure setting. When the adjustment (1) is rotated fully counter-clockwise, no force is applied to the regulating spring (2), and the valve (6) is held closed by the valve spring (7). clockwise rotation of the adjustment (1) compresses the regulating spring (2) which applies a downward force on top of the diaphragm (4). The diaphragm (4) and valve pin (5) move downward forcing valve (6) off its seat (10) which allows air to flow through the regulator to the downstream system. Outlet pressure increases in the downstream system and sensing chamber (9) and applies an upward force on bottom of the diaphragm (4). The diaphragm (4), valve pin (5); and valve (6) move upward, compressing the regulator spring (2). Upward movement stops when the forces below the diaphragm balance the forces above the diaphragm. When there is no downstream flow demand, the balance of forces occurs with the valve (6) closed. When there is downstream flow demand, the balance of forces occurs when the valve opens sufficiently to compensate for demand, thus maintaining the desired outlet pressure. RELIEVING TYPE REGULATORS. With relieving regulators, outlet pressure can be reduced even though the system is deadended. When the adjustment (1) is turned counterclockwise, the force on the regulating spring (2) is reduced, and air pressure in the sensing chamber (9) moves the diaphragm (4) upward. This upward movement opens the relief passage (8) in the diaphragm and allows air to escape from the outlet side of the regulator through the relief passage (8) and vent (3) to atmosphere. As the outlet air pressure decreases to the reduced pressure setting, the diaphragm moves downward and closes the relief passage. The diaphragm will likewise move upward in a response to an increase in outlet pressure above the regulator setting, allowing air to escape to the atmosphere as described above. However, the flow capacity of the relief passage is limited, and depending upon the source of the overpressure condition, the outlet pressure might increase to a point significantly higher than the regulator setting. For this reason, the relief feature of a regulator must not be relied upon as an overpressure safety device. See WARNING note below.

MAINTENANCE

The regulator can be disassembled for servicing without removal from pipe line. to disassemble, shut off the inlet air and reduce pressure in inlet and outlet lines to zero. Turn adjusting screw (1) counterclockwise until all load is removed from regulating spring (7 or 7a): Remove bonnet screws (4), bonnet (3), upper springrest (5), spring (7), and diaphragm assembly (8). The intermediate springrest (6) and compound spring (7a) are used only on 3/4" (19mm) and 1" (25.4mm) models with 5 to 125 PSI (0.34 to 8.62 Bar) adjustment range. Unscrew and remove bottom plug (16), O-ring (15) and valve spring (14). Pull valve assembly (11) together with O-ring (12) out of body. Do not remove valve seat (10) unless replacement is necessary. Remove O-ring (9) using a hook shaped tool, taking care not to damage O-ring seating surfaces or valve seat. Clean parts using warm water and soap. Dry thoroughly. Inspect each part carefully. Replace any parts which are damaged. At reassembly, apply a wipe coat of silicone base grease to O-rings (9, 12, 15), to stem and body of valve assembly (11), and to center bore in bottom plug (16). Apply a light even coat of light grease to full length of threads and tip of adjusting screw (1). Tighten valve seat (10), if previously removed, to 80-100 inch-pounds torque (9-11.3 N-m) (1/4", 3/8" and 1/2" sizes) (6.35mm, 9.53mm, and 12.77mm sizes) or 25-30 foot-pounds torque (33.9-40.7 N-m) (3/4" and 1" sizes) (19mm and 25.4mm sizes). Tighten bottom plug (16) snugly by hand. Tighten bonnet screws (4) to 20-30 inch-pounds torque (2.3-3.4 N-m) (1/4", 3/8" and 1/2" sizes) (6.35mm, 9.53mm, and 12.77mm sizes) or 50-60 inch-pounds torque (5.6-6.8 N-m) (3/4" and 1" sizes) (19mm and 25.4mm sizes).

ADJUSTMENT

1. Before turning on system air pressure, turn regulator adjustment counterclockwise until all load is removed from regulating spring.
2. Turn on system air pressure.
3. Turn regulator adjustment clockwise until the desired outlet pressure is reached.
4. To avoid minor readjustment after making a change in pressure setting, always approach the desired pressure from a lower pressure. When reducing from a higher to a lower setting, first reduce to some pressure less than the desired, then bring up to the desired point.
5. Tighten jam out to lock pressure setting.

⚠ WARNING

THESE REGULATORS ARE INTENDED FOR USE IN INDUSTRIAL COMPRESSED AIR SYSTEMS ONLY. DO NOT USE THESE REGULATORS WHERE PRESSURE OR TEMPERATURE CAN EXCEED RATED OPERATING CONDITIONS. SEE SPECIFICATIONS.

⚠ WARNING

IF OUTLET PRESSURES IN EXCESS OF THE REGULATOR PRESSURE SETTING COULD CAUSE DOWNSTREAM EQUIPMENT TO RUPTURE OR MALFUNCTION, INSTALL A PRESSURE RELIEF DEVICE DOWNSTREAM OF THE REGULATOR. THE RELIEF PRESSURE AND FLOW CAPACITY OF THE RELIEF DEVICE MUST SATISFY SYSTEM REQUIREMENTS.

⚠ WARNING

BEFORE USING WITH FLUIDS OTHER THAN AIR, FOR NON-INDUSTRIAL APPLICATIONS, OR FOR LIFE SUPPORT SYSTEMS, CONSULT C.A. NOR-GREN CO

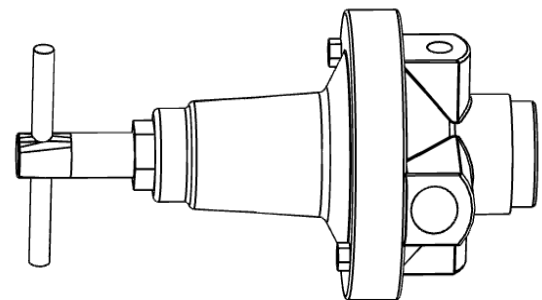

PRESSURE REGULATOR

MINNICH P/N 009626-00010

INSTALLATION

Install regulators so the airflow is in the direction of the arrow as indicated on the head of unit. Regulators should be installed downstream from filters and upstream from lubricators, but as close as possible to the pneumatic tools or appliances being serviced. The regulator will accurately control secondary pressure between 5 and 200 PSI (0.34 and 13.8 Bar), maximum primary pressure is 250 PSI (17 Bar). The self-bleed feature permits use on dead-end applications.

OPERATION ADJUSTMENTS

After the regulator is installed, back off pressure by adjusting T-handle counterclockwise before the air is turned on. Turn on air supply and adjust T-handle clockwise until the pressure gauge shows desired pressure. To lock the T-handle, tighten lock nut on adjustment screw.

MAINTENANCE

On detection of air leaks, pressure fluctuation, or "creep", depressurize system and remove bottom cap. Inspect valve seat for damage or wear. Inspect seat in head casting for foreign material or damage. Clean with naphtha or kerosene and blow out with air. Replace any damaged parts. If leaks persist, remove spring cage, inspect piston and piston seat for wear or foreign materials. Replace any damaged Parts.

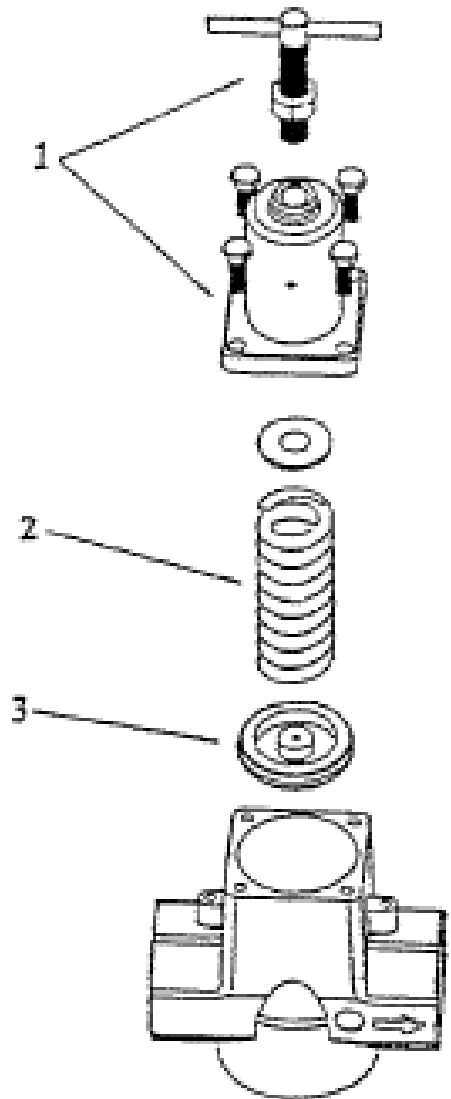

PART NUMBER	ITEM	KIT DESCRIPTION	CONTENTS
011703-00004	2, 3	Valve Kit	Valve Assembly, Valve Spring, O-Ring
011703-00003	3	Piston Kit	Relieving Piston Assembly (STD)
011703-00002	2	Spring Kit	Spring, 0-125 PSI (0-8.6 Bar) Range (STD)
011703-00001	1	Spring Cage Kit	T-Handle Adjusting Screw Assembly, Spring Cage, Screws

⚠ WARNING

FOR COMPRESSED AIR SERVICE ONLY. NOT TO BE USED ON LIFE SUPPORT SYSTEMS.

⚠ WARNING

Units are die cast aluminum. Do not over torque when installing regulator or gauge. Use of Teflon tape is not recommended.

REVISIONS			
REV.	DESCRIPTION	DATE	APPROVED
A	REMOVED A13677; ADDED A12075 AND (2) 3016-44	10/11/2021	AEB

ITEM NO.	PART NUMBER	DESCRIPTION	DRILL UP/QTY.
1	3016-44	HANDLE - GRIP	4
2	5221	WHEEL - INDUSTRIAL	2
3	6038-2.75	HHCS, 3/8-16 X 2.75 GR.5	2
4	6404	LOCKNUT 3/8"	2
5	10084	NON-SLIP TRACK ADHESIVE BLACK	6"
6	A9360	MINNICH 50# DRILL	1
7	A11388-36*	DECAL, KIT FOR: A1 36	1
8	A12057-13	FRAME AND RAIL ASSY. A-1-36	1
9	A12058-4	CONTROL AND LUBRICATOR ASSEMBLY	1
10	A12059	A-1 WHEEL ASSEMBLIES	1
11	A12059-9	FRONT WHEEL ASSEMBLY	1
12	A12075	HANDLE WELDMENT	1
13	13270-4*	SPRING WHIP CABLE ASSEMBLY	2

*NOT SHOWN

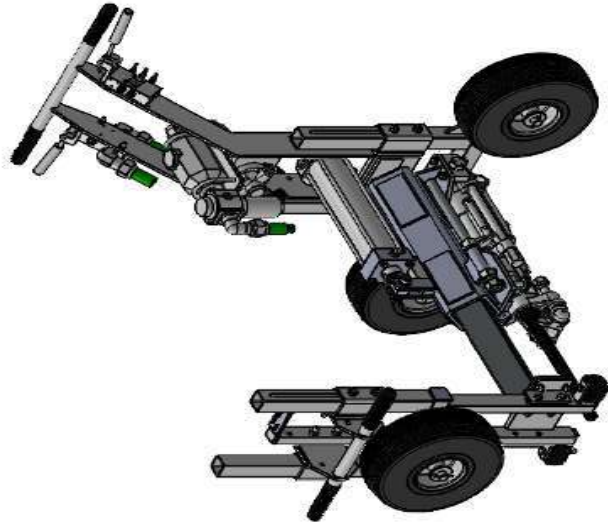
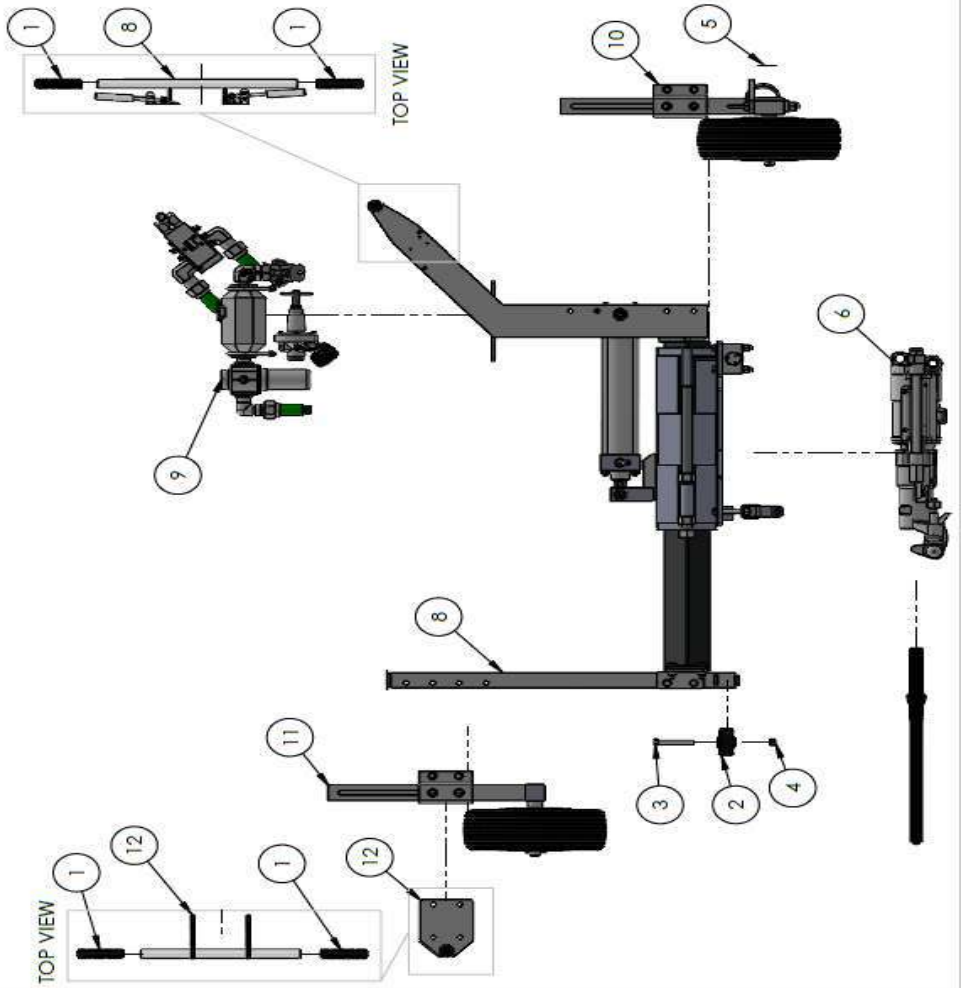

SALES/REGIONAL MANAGER	MANUFACTURING	DATE
MAGNETEC MACHINERY, INC.		
THIS DRAWING IS THE PROPERTY OF MAGNETEC MACHINERY, INC. IT IS TO BE USED ONLY FOR THE PROJECT AND PRODUCT SPECIFICALLY IDENTIFIED ON THIS DRAWING.		
DRAWN BY: AEB	CHECKED BY:	APPROVED BY:
DO NOT SCALE DRAWING		
TITLE: Dimension in accordance with ANSI Y14		
DRILL, A-1 36		
FIGURE NO.	LOCATION	ROUTING NO. DRAWING NUMBER:
		A12060-13
TOLEANCES: (UNLESS NOTED) X .0005 Y .001 Z .005	X/XK ± 1/16" Y/YK ± 1/8" Z/ZK ± 1/4"	REV. LEVEL A

ITEM NO.	PART NUMBER	DESCRIPTION	QTY.
1	3016-44	HANDLE - GRIP	2
2	5221	WHEEL - INDUSTRIAL	2
3	6038-2.75	HHCS, 3/8-16 X 2.75 GR.5	2
4	6404	LOCKNUT 3/8"	2
5	10084	NON-SLIP TRACK ADHESIVE BACKED BLACK	1
6	A9350	DRILL, AIR 7/8 X 4-1/4 CHUCK TOYO 50 LB	1
7	A11388-36	DECAL KIT FOR A1-36	1
8	A12057-13	FRAME AND RAIL ASSY, A-1-36	1
9	A12058-4	CONTROL AND LUBRICATOR ASSEMBLY	1
10	A12059	A-1 WHEEL ASSEMBLIES	1
11	A12059-9	FRONT WHEEL ASSEMBLY	1
12	A13270-4	SPRING WHIP CABLE ASSEMBLY	2
13	A13617	HANDLE ASSEMBLY	

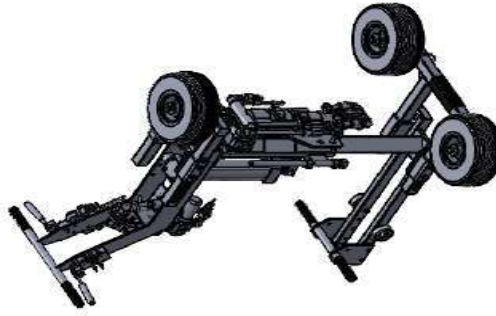
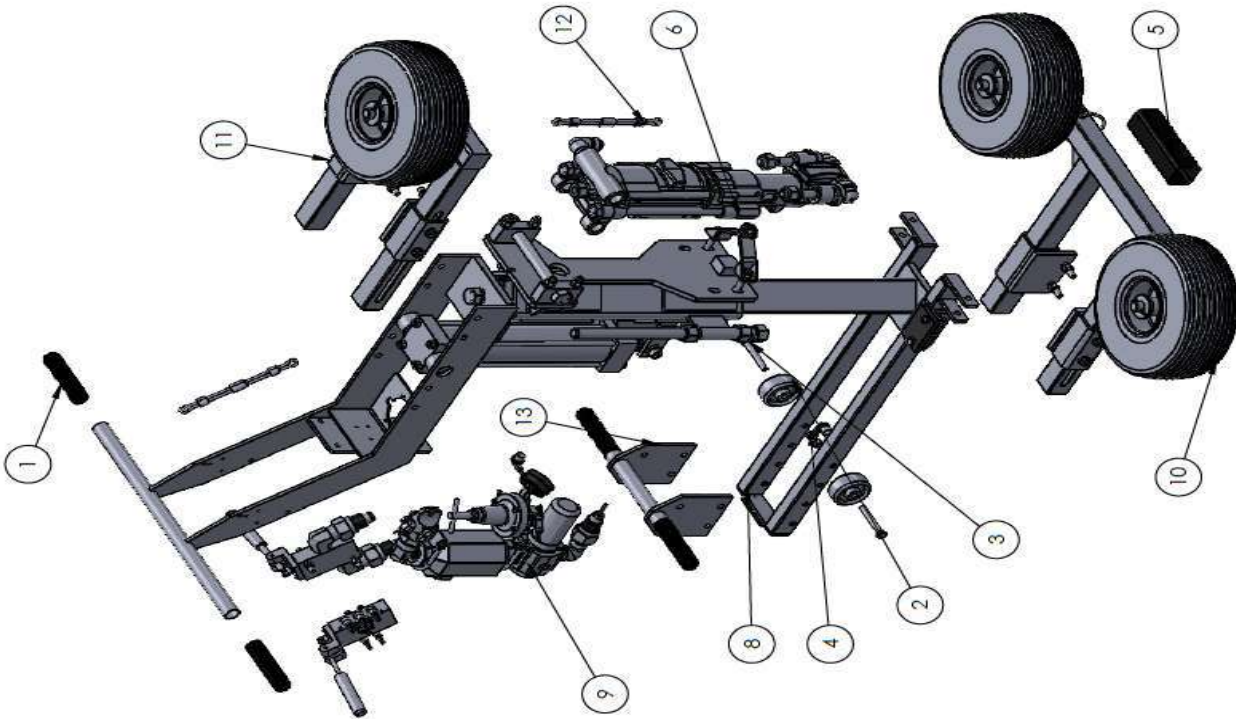

#	MANUAL/ISSUE/MATERIAL	LOCKER
MINDSPRING CO., INC. INFORMATION: Please refer to the following information for more details on our products and services. RETURN TO: MINDSPRING CO., INC. 10000 N. 10TH AVE. SUITE 100, DENVER, CO 80231		
DO NOT SCALE DRAWING		
TOLERANCES (UNLESS NOTED)	Dimension in accordance with ANSI Y14	
F	± .000	
M	± .005	
XX	± .006	
XXX	± .008	
FR	± 1/16"	
LR	± 1"	
TITLE:		DO NOT SCALE DRAWING
A-1-36 VERTICAL DRILLING ASSEMBLY		
ROUTING NO.	LOCATION	REV. LEVEL
A12060-13V		
DRAWN BY:	APPROVED BY:	ORG. DATE
RJ		08/19/2020
CHECKED BY:		

NOT SHOWN:
A11388-36 DECAL KIT FOR A1-36

ITEM NO.	PART NUMBER	DESCRIPTION	QTY.
1	1811	COUPLING - HOSE 2 PRONG/MALE PIPE	1
2	1864	LUBRICATOR	1
3	2880	AIR REGULATOR	1
4	3656	PRESSURE GAUGE	1
5	3820	SAFETY PIN & LANYARD	1
6	3997	HOSE, 3/4 ID, 250 PSI	96"
7	5856	PLUG - AIR HOSE COUPLING	1
8	6000-14	3/4 NPT PIPE	1
9	6018-1	ELBOW - 45 DEG	1
10	6019-19	90 DEG. ELBOW - EXT. PIPE / 37 DEG.	2
11	6019-24	90 DEG. ELBOW W/ 37 DEG. FLARE	1
12	6032-6	END HOSE 37 DEG. SWIV/BARDED 12	4
13	6036-2.00	HEX BOLT 1/4-20 X 2	2
14	6104	1/4 USS FLAT WASHER	4
15	6144	LOCK WASHER #8	3
16	6256-1.50	RHMS, #8-32 X 1-1/2 SLOTTED	3
17	6296-1	BUSHING, REDUCER PIPE 06-04	2
18	6402	1/4-20" LOCKNUT	6
19	6471-4	PLUG, PIPE HEX SOC 1/2	1
20	6653	HEXNUT 8-32	3
21	6721-0.75	SCREW, MS #12-24 X 3/4 FILLISTER SLOTTED	4
22	8454	U-BOLT, LUBRICATOR MOUNT	2
23	9626-10	AIR REGULATOR - PRESET 96 PSI	1
24	10300	VALVE LEVER EXT.	2
25	10829-10	1/4 NPT PIPE	7
26	10829-11	FITTING, MALE ELBOW 1/4 TUBE TO 3/8 MALE NPT	2
27	10831-8	FITTING, MALE BRANCH TEE 1/4 TUBE TO 1/4 MALE NPT	1
28	10863	1/4" NYLON TUBING	160"
29	10872-1	1/2" EXPANDABLE SLEEVING	30"
30	11879-1	90 DEG ELBOW MODIFICATION	1
31	13058	2 POS SPRING RETURN VALVE	1
32	13059	VALVE	1

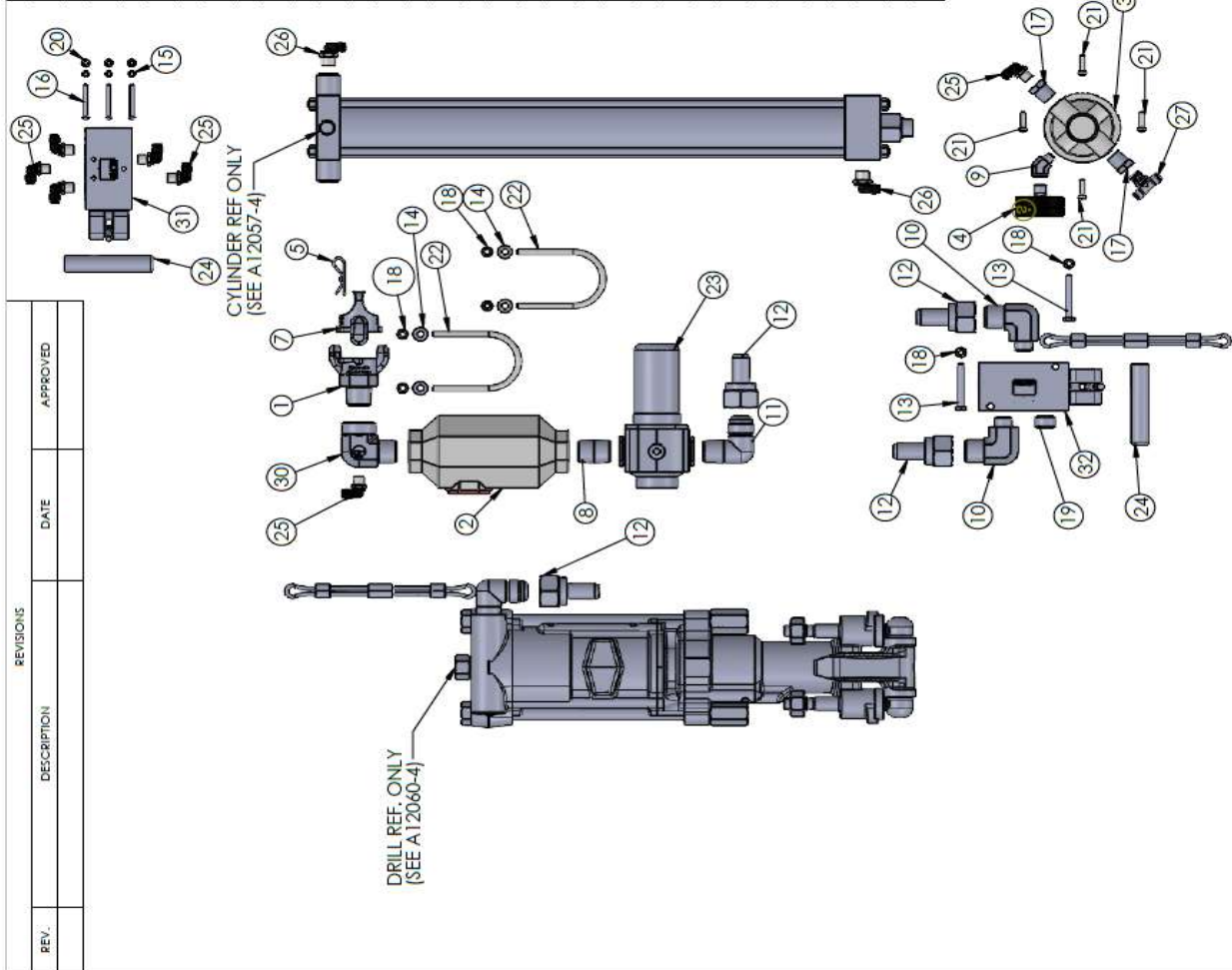

REVISIONS		DATE	APPROVED
REV.	DESCRIPTION		

SAFETY MANUAL

MANUFACTURE USE, INC.
 5000 INDUSTRIAL WAY, FORT WORTH, TEXAS 76116, USA
 ESTABLISHED IN 1952. A DIVISION OF MANULIFE.

DRAWING BY: RJ
 CHECKED BY: JLS
 APPROVED BY: JLS

DO NOT SCALE DRAWING

TOLERANCES UNLESS OTHERWISE SPECIFIED:
 X .000
 XX .005
 XXX .010
 XXXX .015

TITLE:
 Dimension in accordance with ASME Y14

LOCATION: ROUTING NO. DRAWING NUMBER: A12058-4

DATE: 11/10/2021
REV. LEVEL: 1

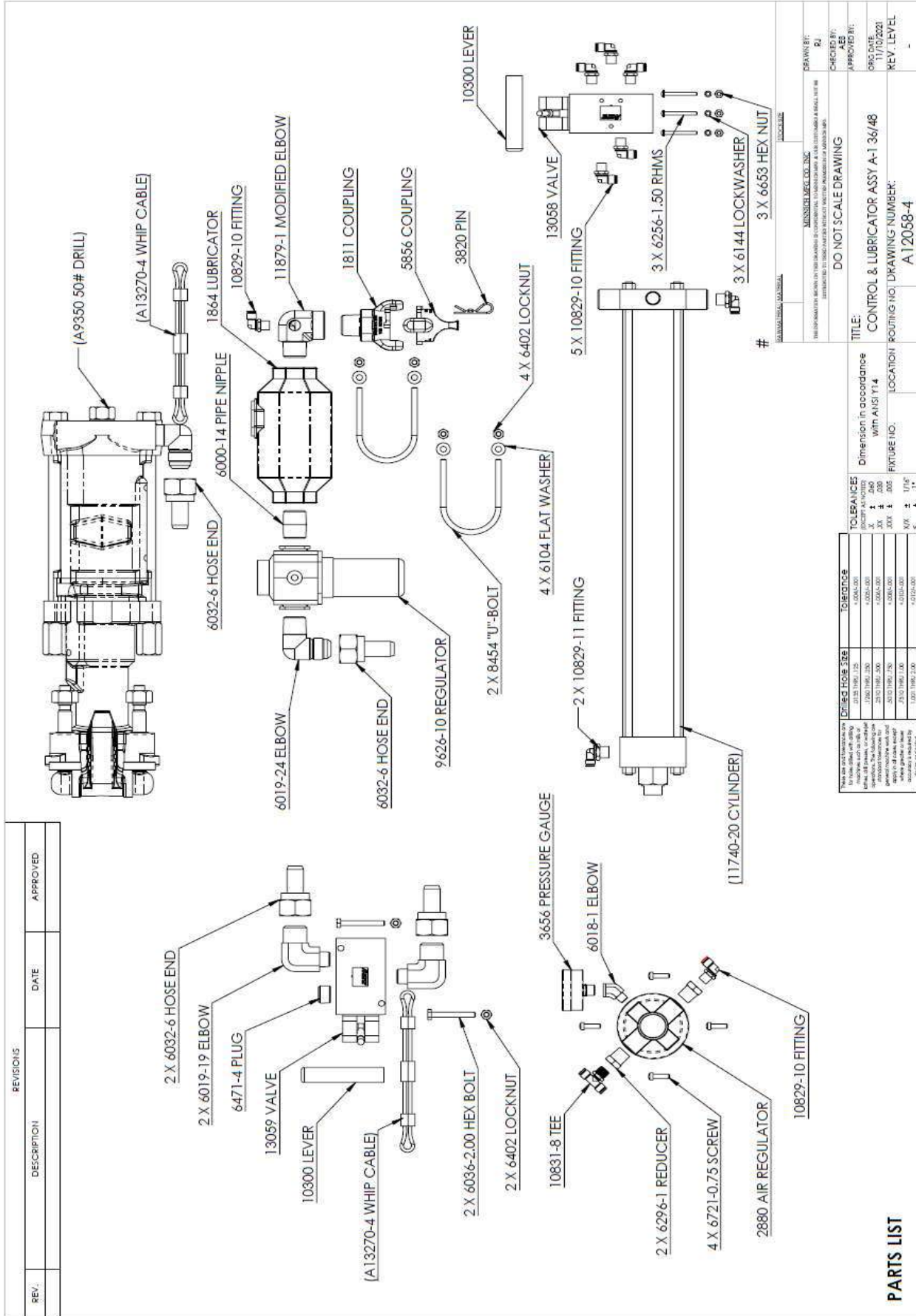

REVISIONS		DATE	APPROVED
REV.	DESCRIPTION		

TOLERANCES		DIMENSIONS	
FRONT VIEW	± 0.0005	LENGTH	± 0.0005
TOP VIEW	± 0.0005	WIDTH	± 0.0005
RIGHT SIDE VIEW	± 0.0005	HEIGHT	± 0.0005
LEFT SIDE VIEW	± 0.0005	DEPTH	± 0.0005
REAR VIEW	± 0.0005	DIAMETER	± 0.0005
ISOMETRIC VIEW	± 0.0005	ANGLE	± 0.0005
SECTIONAL VIEW	± 0.0005	SPACING	± 0.0005
DETAIL VIEW	± 0.0005	SCALE	± 0.0005

DESIGNED BY: R.J.	CHECKED BY: R.J.
DRAWN BY: R.J.	APPROVED BY: R.J.
DO NOT SCALE DRAWING	
TITLE: CONTROL & LUBRICATOR ASSY A-1 36/48	
DATE: 11/07/2021	
REV. LEVEL: 1	
DRAWING NUMBER: A12038-4	

PARTS LIST

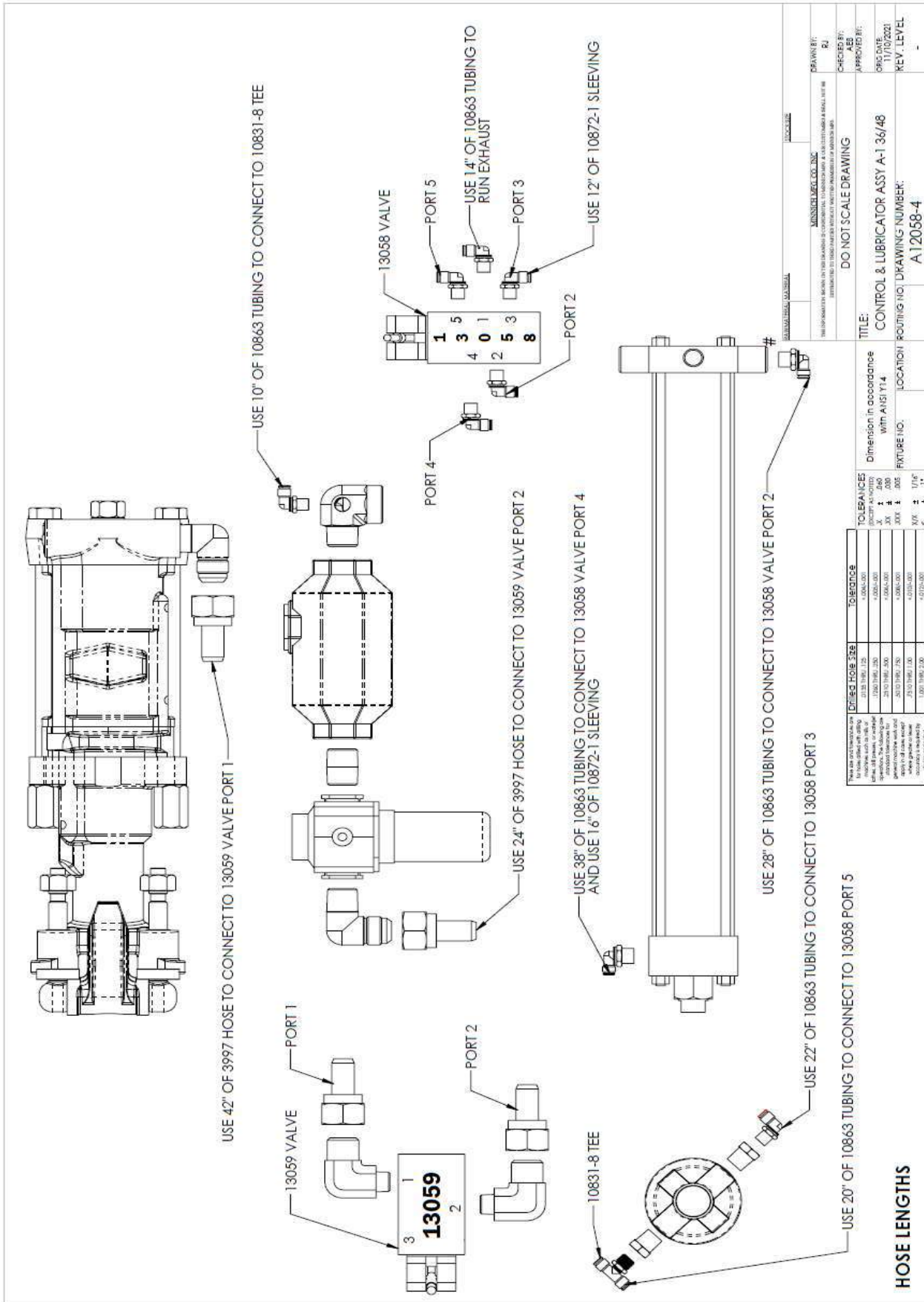

LUBRICATOR

MINNICH P/N 001864-00000

CAPACITY: 0.5 PINT (237mL)

PIPE SIZE: 3/4" (1.9cm) N.P.T.

ITEM NUMBER	MINNICH PART NUMBER	DESCRIPTION
1	001864-00001	Feeder Assembly Kit
2	001864-00002	Manual Relieving Safety Cap
4	001864-00003	Sight Window
6	001864-00004	Check Valve (Constant Feed)
	006412-00916	Filler Cap O-Ring
	006412-00905	Feeder O-Ring

LUBRICATOR IS SET AT 5.5 FROM FACTORY. DIFFERENT TEMPERATURES MAY AFFECT FLOW OR OIL. YOU MIGHT HAVE TO ADJUST LUBRICATOR ACCORDINGLY. BE SURE LUBRICATOR IS SET SO THAT YOU ALWAYS HAVE A LIGHT FILM OF OIL ON EXHAUST DEFLECTOR.

TO ADJUST LUBRICATOR, DISCONNECT AIR PRESSURE FROM DRILL UNIT. PUSH DOWN ON PRESSURE RELIEVING BUTTON ON FILL CAP. REMOVE FILL CAP. USING A SCREW DRIVER, ADJUST LUBRICATOR TO REQUIRED SETTING. TO INCREASE OIL, SET AT HIGHER NUMBER. TO DECREASE OIL, SET AT LOWER NUMBER.

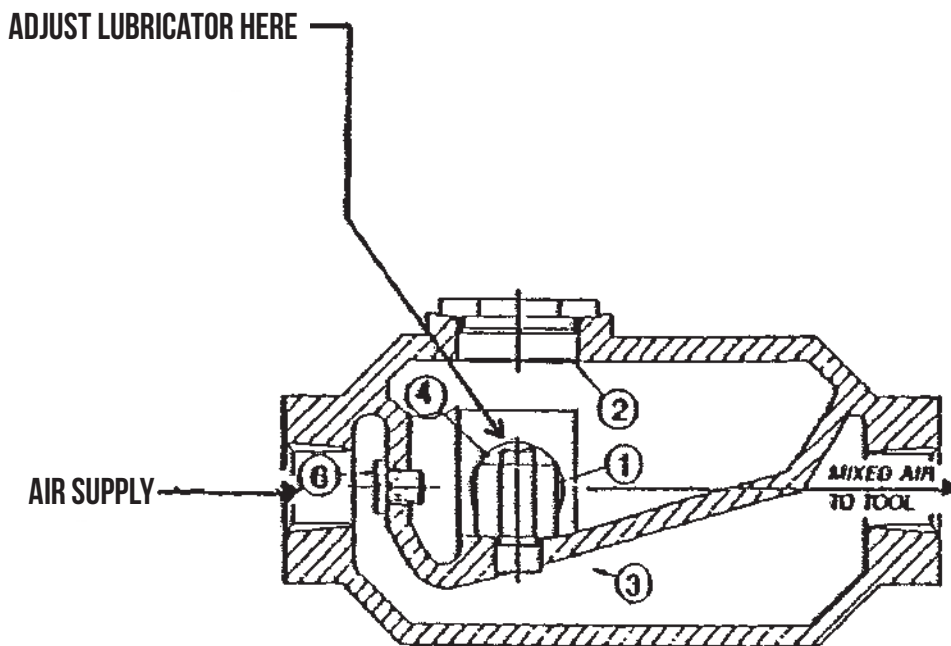

50# (23KG) ROCK DRILLOA9350-00000

When ordering replacement parts you need to furnish the model and serial number of the drill tool.

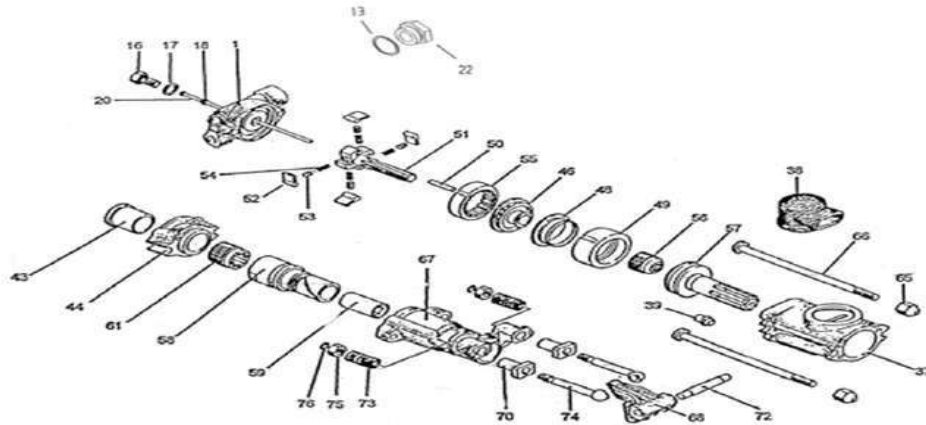

FIG.	PART #	DESCRIPTION	QTY	FIG.	PART #	DESCRIPTION	QTY
1	009350-00001	BACKHEAD ASSEMBLY	1	56	009350-00056	RIFLE NUT	1
13	009350-00013	AIR CONNECTION WASHER	1	57	009350-00057	PISTON	1
16	009350-00016	BLOW TUBE GLAND	1	58	009350-00058	ROT. SLEEVE 1" X 4-1/4" (2.5cm X 10.8cm)	1
17	009350-00017	TUBE GLAND GASKET	1	59	009350-00059	SLEEVE BSG 1" HEX. X 4-1/4" (2.5cm HEX X 10.8cm)	1
18	009350-00018	BLOW TUBE GASKET	1	59A	009350-0059A	SLEEVE BSG 7/8" HEX. X 4-1/4" (2.2cm X 10.8cm)	1
20	009350-00020	BLOW TUBE	1	61	009350-00061	SLEEVE NUT	1
22	009350-00022	PLUG ADAPTER	1	65	009350-00065	SIDE ROD NUT	2
37	009350-00037	CYLINDER	1	66	009350-00066	SIDE ROD	2
38	009350-00038	EXHAUST DEFLECTOR	1	67	009350-00067	FRONTHEAD 1" X 4-1/4" (2.5cm X 10.8cm)	1
39	009350-00039	BLOWING CONNECTION	1	68	009350-00068	STEEL RET. 1" X 4-1/4" (2.5cm X 10.8cm)	1
43	009350-00043	FRONT WASHER BUSHING	1	68A	009350-0068A	STEEL RET. 7/8" X 4-1/4" (2.2cm X 10.8cm)	1
44	009350-00044	FRONT WASHER	1	70	009350-00070	FRONTHEAD BSG.	2
46	009350-00046	VALVE CHEST COVER	1	72	009350-00072	STEEL RET. PIN	1
48	009350-00048	AUTOMATIC VALVE	1	73	009350-00073	STEEL RET. SPRING	2
49	009350-00049	VALVE CHEST	1	74	009350-00074	STEEL RET. BOLT	2
50	009350-00050	VALVE DOWEL PIN	1	75	009350-00075	STEEL RET. NUT	2
51	009350-00051	RIFLE BAR	1	76	009350-00076	STEEL RET. CLIP	2
52	009350-00052	ROTATION PAWL	4				
53	009350-00053	PAWL PLUNGER	4				
54	009350-00054	PAWL SPRING	4				
55	009350-00055	RATCHET RING	1				

SPECIFICATIONS

Net Weight	51lbs. (23kg)
Blows Per Minute	2300
Chuck Size	7/8" x 4 1/4" (22.2mm x 107.9mm)
Air Inlet (NPT)	3/4" (19.1mm)
Air Consumption	92.2cfm (2.6m ³ /min)

⚠ WARNING

Always disconnect the air supply before changing steel or dismantling the tool for service or repair. For maximum safety we advise the installation of a shut-off valve at the end of the air line.

NOTES

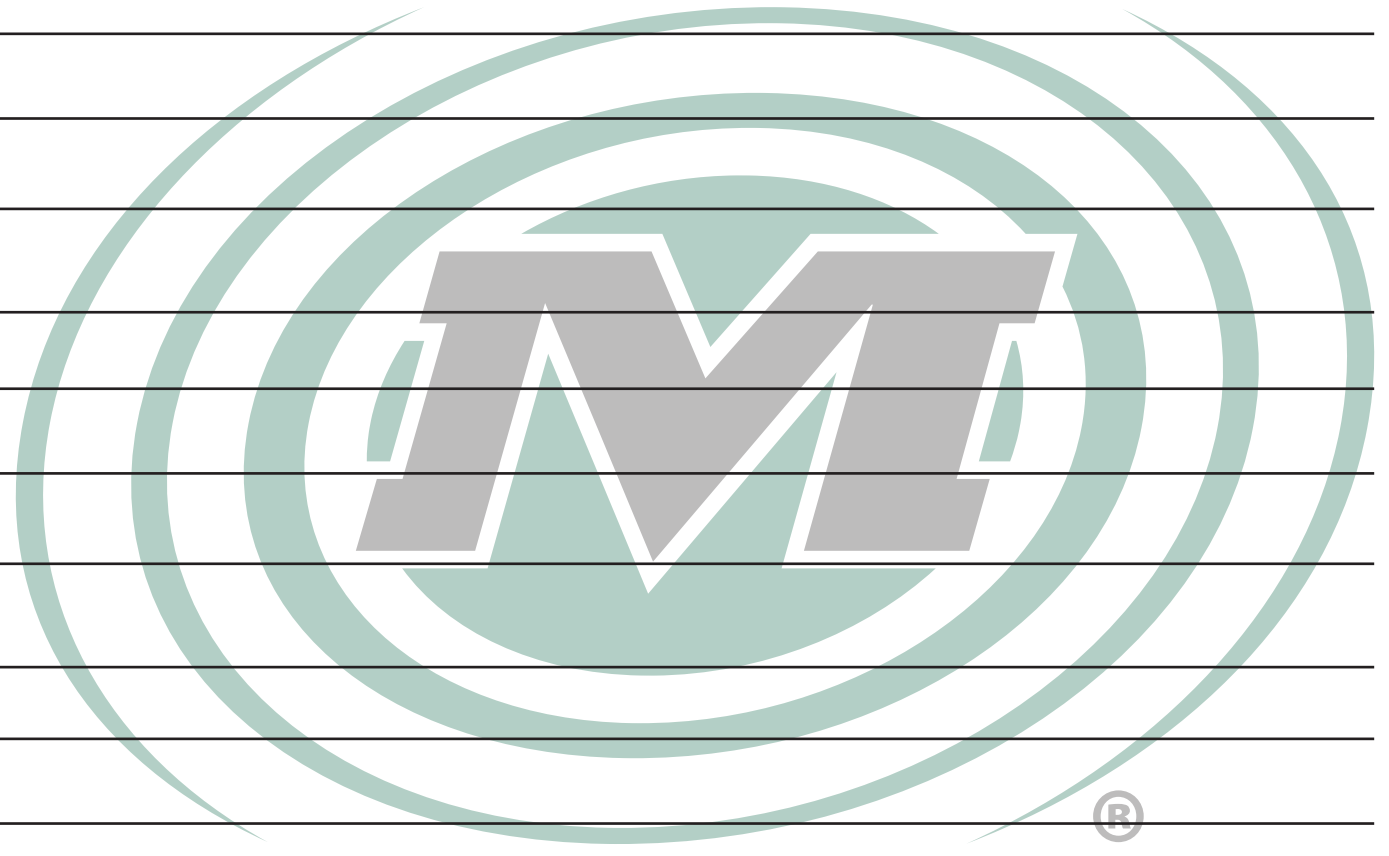

LIMITED WARRANTY, DISCLAIMER

Supplier warrants to Customer that the Services shall be provided in a workmanlike manner and that the Goods shall be free from defects in material and workmanship at the date of shipment from Supplier's facility. This warranty shall not run to any person other than Customer. All claims under this warranty must be made in writing and delivered to Supplier prior to the expiration of one (1) year after the Goods have been delivered (or, if applicable, within one (1) year after the Services have been performed) or be forever barred. Supplier will repair or replace Goods or parts recognized and acknowledged by Supplier as being defective at the time of delivery without charge. However, Supplier will bill Customer for Goods and/or Services not covered by the warranty, including travel expenses incurred while performing warranty service calls. EQUIPMENT, COMPONENTS OR OTHER GOODS FURNISHED THAT ARE NOT MANUFACTURED BY SUPPLIER ARE ONLY COVERED TO THE EXTENT OF THE ORIGINAL MANUFACTURER'S WARRANTY, WHICH MAY VARY FROM THE ABOVE. Further, the above warranty shall not apply to any hardware or software that has been repaired or altered without Supplier's written permission by anyone other than Supplier's personnel. The foregoing states the sole and exclusive remedy for any breach of warranty or for any other claim based on any defect in, or non-performance of, the Goods or Services, whether based upon contract, warranty, negligence, tort (including strict liability) or otherwise.

NO EXPRESS WARRANTIES AND NO IMPLIED WARRANTIES, WHETHER OF MERCHANTABILITY OR FITNESS FOR ANY PARTICULAR PURPOSE OR WEAR CAPACITY, OR OTHERWISE, SHALL APPLY TO THE GOODS AND SERVICES. SUPPLIER SPECIFICALLY DISCLAIMS AND EXCLUDES ALL OTHER EXPRESS AND IMPLIED WARRANTIES. NO WAIVER, ALTERATION, ADDITION OR MODIFICATION OF THE FOREGOING SHALL BE VALID UNLESS MADE IN WRITING AND SIGNED BY AN EXECUTIVE OFFICER OF SUPPLIER. IN NO EVENT WILL SUPPLIER BE LIABLE FOR ANY INCIDENTAL OR CONSEQUENTIAL DAMAGES.

WHAT IS NOT COVERED

This Limited Warranty does not cover any damage, deterioration or malfunction resulting from normal wear or tear, or any alteration, modification, improper or unreasonable use or maintenance, misuse, abuse, accident, neglect, exposure to excess moisture, fire, improper packing and shipping (such claims must be presented to the carrier), lightning, power surges, or other acts of nature. This Limited Warranty does not cover any damage, deterioration or malfunction resulting from the installation or removal of this product from any installation, any unauthorized tampering with this product, any repairs attempted by anyone unauthorized by Minnich to make such repairs, or any other cause which does not relate directly to a defect in materials and/or workmanship of this product.

WHAT IS COVERED

This limited warranty ("Limited Warranty") covers manufacturing defects in materials and workmanship of a product.

WHO IS COVERED:

Only the original purchaser of this product is covered under this Limited Warranty. This Limited Warranty is not transferable to subsequent purchasers or owners of this product. The product must have been purchased directly from Minnich or from an authorized Minnich reseller.

ORDER VIA INTERNET!



Order Online:
<https://www.minnich-mfg.com/login>



- View parts
- Order Parts
- Print specific information
- If you don't have a login give us a call.

ORDER VIA PHONE!



Contact us at:
419-903-0010

WE ACCEPT THE FOLLOWING CARDS!



DISCOVER



SCAN FOR HELPFUL VIDEOS!



NON-DEALER AND INTERNATIONAL CUSTOMERS:

Contact Minnich Manufacturing through the following number to locate a dealer near you.
(419-903-0010)

NOTICE

All orders are treated as Standard Orders and will ship the same day if received prior to 3PM EST