



ORIGINAL OPERATING INSTRUCTIONS

Contents

1. General information	3–4
2. Description	5–12
3. Tools and accessories	13–16
4. Technical data	17–20
5. Safety precautions	21–25
6. Preparing the saw system for use	27–37
7. Operating the equipment	39–41
8. Care and maintenance	43–48
9. Troubleshooting	49–55
10. Disposal	56
11. Manufacturer's warranty – tools	57
12. EU declaration of conformity (original)	58

1. General information

1.1 Safety notices and their meaning

The operating instructions must be read carefully before the equipment is put into operation. Always keep these operating instructions with the equipment. The wire saw system should be handed over to other persons only complete with the operating instructions.

DANGER

Draws attention to imminent danger that will lead to serious bodily injury or fatality.

WARNING

Draws attention to a potentially dangerous situation that could lead to serious personal injury or fatality.

CAUTION

Draws attention to a potentially dangerous situation that could lead to slight personal injury or damage to the equipment or other property.

NOTE

Draws attention to an instruction or other useful information.

1.2 Explanation of the pictograms and other information

Warning signs

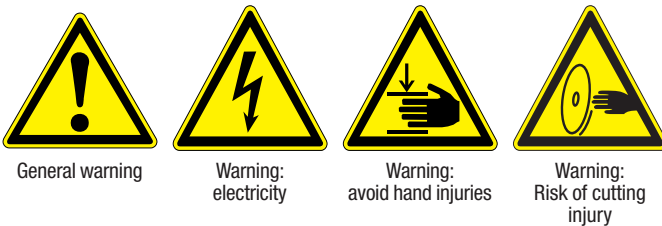

Obligation signs



Symbols

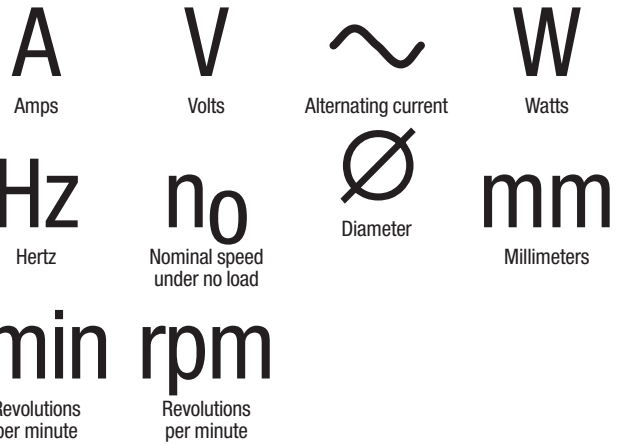
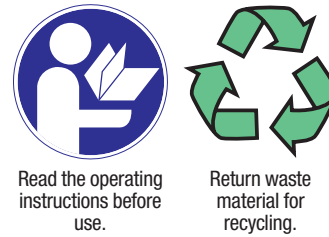

On the machine



To avoid damage, do not exceed a water pressure of 6 bar.

To avoid damage when there is a risk of freezing, the cooling circuit of the system must be blown out with compressed air after use.

On the control unit

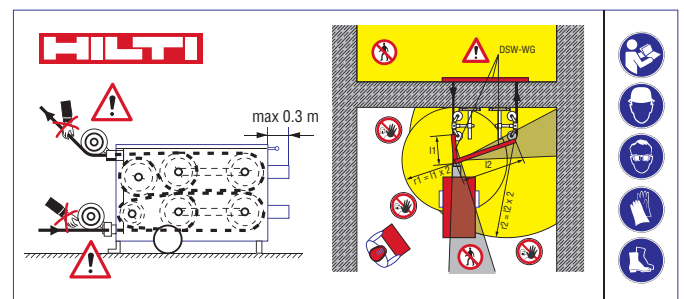

1. General information



- ① Drive unit with 2 motors, wire storage unit, guide pulleys, wheel assembly and electric cable for connection to the control unit
- ② Control unit
- ③ Air compressor
- ④ Air hoses (2×7 m, 1×1 m)
- ⑤ Single pair pulley stand
- ⑥ Water nozzle – long
- ⑦ Water nozzle – flexible
- ⑧ Water hoses
- ⑨ Tool set
- ⑩ Wire guard

Description	2.1 Areas of application	6
	2.2 DS WS 15 basic system units	6
	2.3 Operating controls	6
	2.4 Drive principle	11
	2.5 Saw advance and wire storage	11
	2.6 Wire guidance	12
	2.7 Safety concept for the working area	12

2. Description

2.1 Areas of application

The DS WS 15 is an electrically-powered wire saw which, by means of its diamond wires, is capable of sawing through construction materials ranging from heavily reinforced concrete to metre-thick masonry. Equipped with the appropriate accessories, it can be used to cut openings of all kinds and for the technical demolition of construction components of any shape, thus presenting almost limitless application possibilities. Sawing operations are normally carried out wet, using water cooling, but masonry can also be sawn dry.

2.2 DS WS 15 basic system units

The basic equipment consists of the following components: drive unit, control unit, compressor, 2 single-pair pulley stands, 1 toolbox containing tools and accessories, 2 water supply nozzles.



① Drive unit with 2 motors, wire storage unit, guide pulleys, wheel assembly and electric cable for connection to the control unit

② Control unit complete with plug for a 400 V connection to the electric supply network

③ Compressor (230 V) for the compressed air supply to the pneumatic advance system

④ DS-WS-SPP single-pair pulley stand
The basic equipment includes 2 single-pair pulley stands. These are adequate for most applications but it is also possible to use more than 2 single-pair pulley stands for applications where access is difficult (in cellars, corners, shafts).

⑤ Toolbox containing accessories and tools

⑥ Long water supply nozzle
For use at the rear of the object being cut, deep in the saw kerf.

⑦ Flexible water supply nozzle
For use at the wire entry point on the return side (slack side) located at the front of the object being cut.

2.3 Operating controls

① DS WS 15 drive unit



- 1** T-shaped transportation handle, pull-out type
- 2** Folding transportation handle
- 3** Transportation or lifting lever for raising the wheels
- 4** Lifting points for transportation by crane

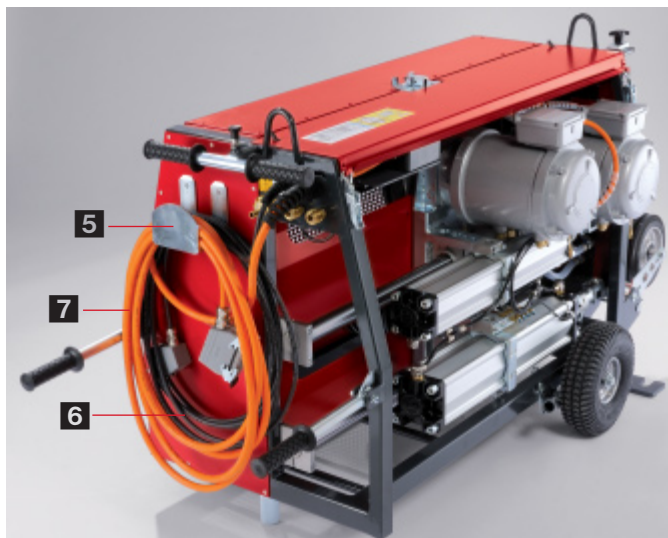

- 5** Cable and hose storage compartment
- 6** 400 V electric cables for drive motors
- 7** 24 V electric cable for control system



- 8** 2 compressed air connections for advance pressure cylinder
- 9** 1 water connection, water supply from construction site

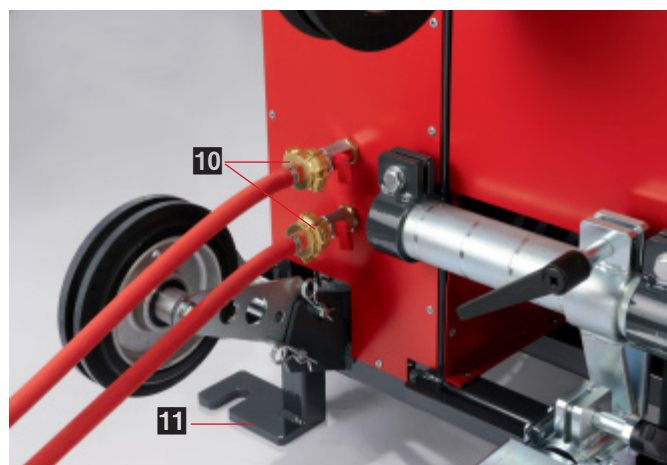

- 10** 2 water connections for cooling water supply to the diamond wire
- 11** 2 baseplates for securing the drive unit to the floor or ground

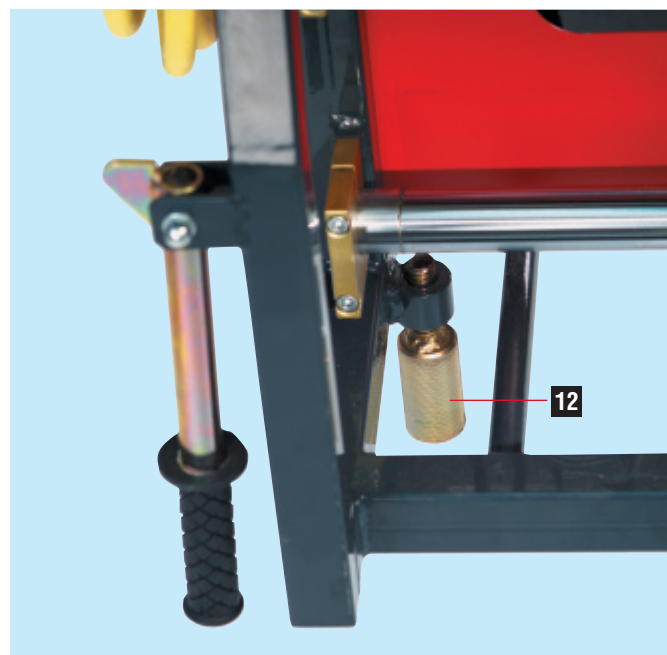

- 12** Three-point supports, adjustable in height

2. Description



- 13** Drive wheel 1, 280 mm dia., fixed
- 14** Drive wheel 2, 280 mm dia., moving, for saw advance
- 15** Storage pulleys, 280 mm dia., moving, for saw advance
- 16** Storage pulleys, 200 mm dia., fixed, for wire storage

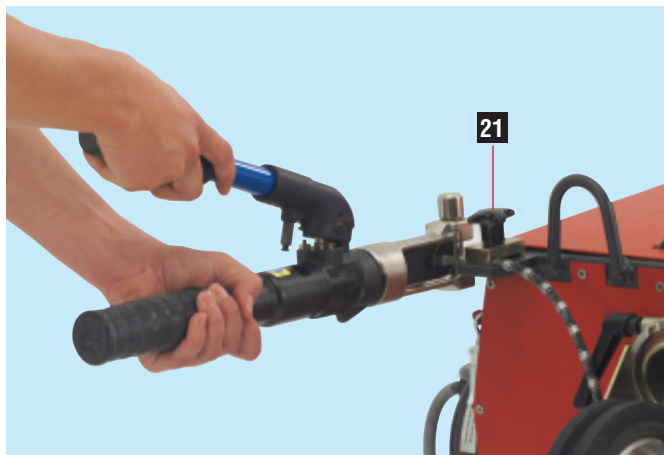

21 Wire clamping vice

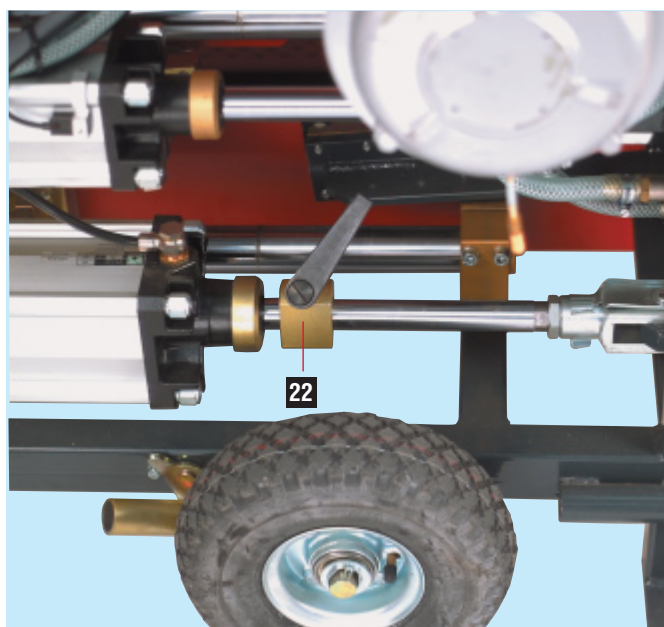

22 Compressed air cylinder stop piece



- 17** Tension-side guide pulley, adjustable in direction and position
- 18** Diamond wire lead-in guide
- 19** Slack-side guide pulley – adjustable in direction
- 20** Cylindrical socket for vertical sawing device or for grip bar



23 Protective cover

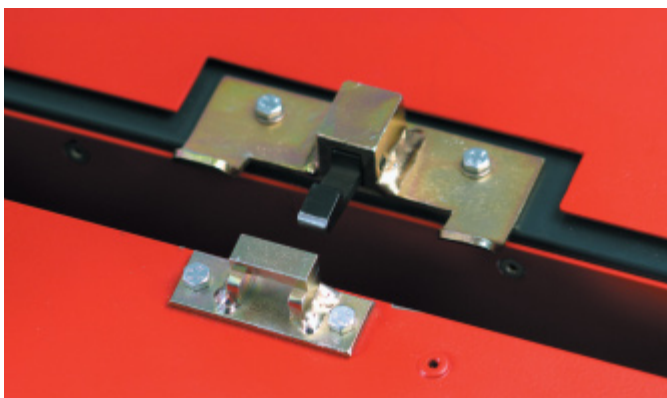

24 Protective cover securing latch

2.3 Operating controls

② DS WS 15 control unit

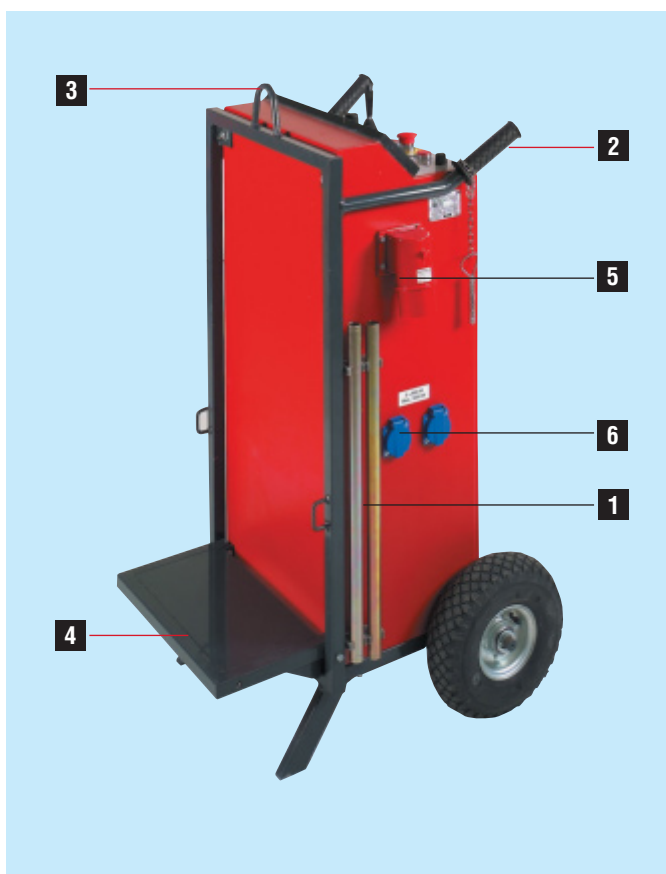

- 1** Transportation and lifting bars
- 2** Transportation handles
- 3** Lifting point for transportation by crane
- 4** Folding shelf for the compressor
- 5** 400 V, 32 amp socket, supply from electric mains
- 6** Two 230 V sockets



- 7** Ventilation grille
- 8** 400 V, 32 amp socket, supply to the drive motors
- 9** 24 V control circuit socket for the drive unit
- 10** Compressed air supply, supply from the compressor
- 11** 2 compressed air connections, supply to the drive unit

2. Description



- 12** Control unit cover lock
- 13** Key for control unit cover lock
- 14** DS WS 15 main power switch
- 15** Digital display for wire cutting speed in m/s
- 16** Green “Ready for operation” indicator light (main power switch ON)
- 17** Red “Error” indicator light - see troubleshooting section
- 18** Yellow light - “Pneumatic advance at rear stop”
- 19** White light - “Water coolant valve open”
- 20** Ammeter
- 21** Advance pressure in bar
- 22** Regulator for wire drive speed of rotation (controls cutting speed, see **15**)
- 23** Drive ON, green light
- 24** Drive OFF, red button
- 25** Emergency STOP button
- 26** Water supply, I = ON, green light
- 27** Water supply, O = OFF, red button
- 28** Advance control system ↑ ↓ forward or back
- 29** Advance pressure regulator , rotary knob (note pressure in bar, see **21**)
Pushed in = locked, pulled out = unlocked

2.4 Drive principle

The wire is driven by 2 electric motors fitted with drive wheels. The diamond wire is fed around the drive wheels in the form of a figure eight to ensure optimum grip. The motors' performance characteristics and control sys-

tem are designed to achieve high initial torque and working torque.

The wire speed can be infinitely adjusted within the 0–27 m/s range.

2.5 Saw advance and wire storage

The wire advance operates according to the principle of a block and tackle working in reverse. The advance movement, causing the wire to be drawn in, is effected by two compressed air cylinders working in opposing direc-

tions. Accordingly, the rear pulleys (storage pulleys, 280 mm dia.) are mounted on a moving carriage. The maximum wire storage capacity is 9.2 m. The minimum length of wire required by the drive system is 3.2 m.

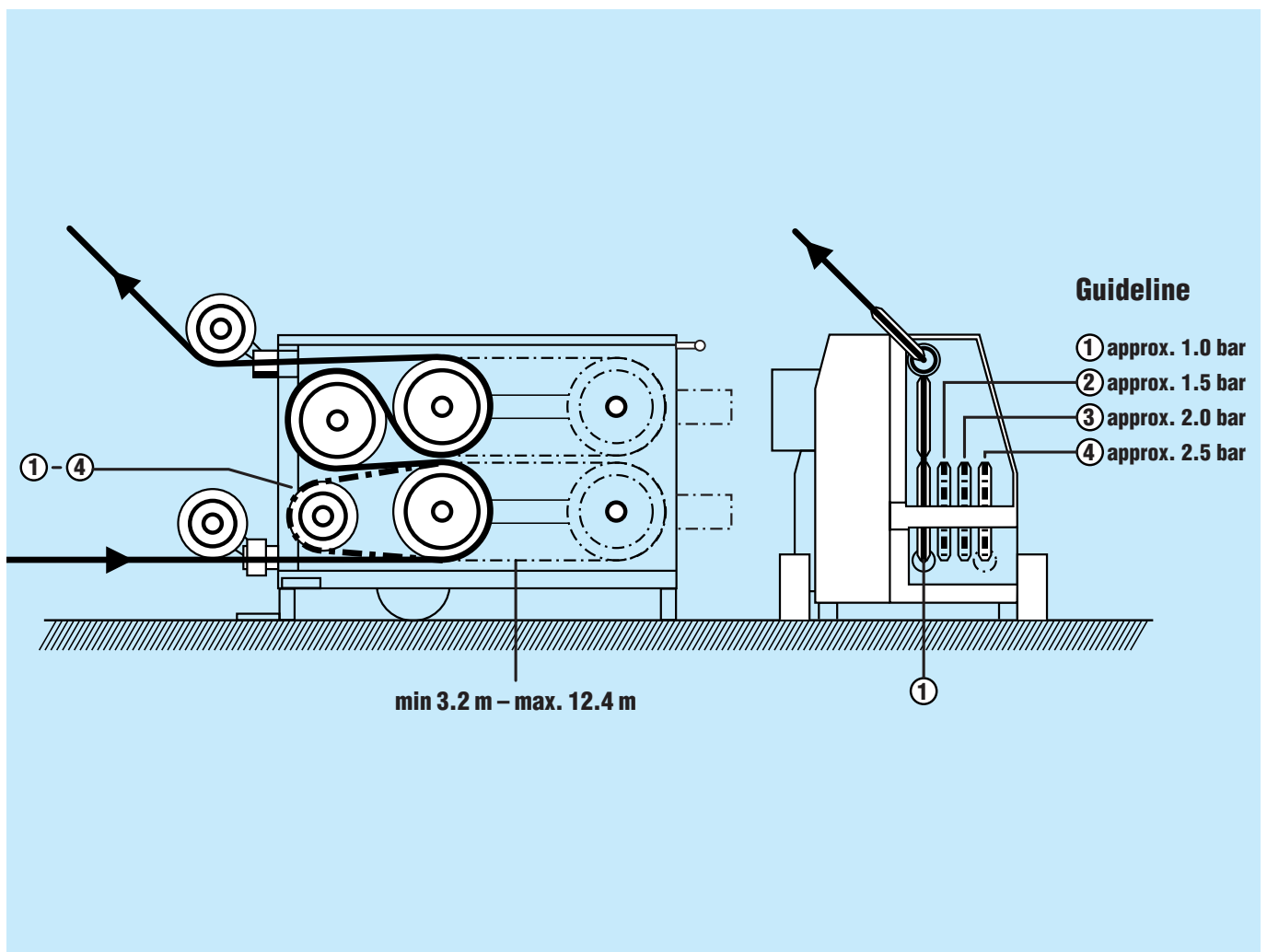

Wire capacity	Wire in drive	Wire storage	Material thickness
Basic capacity	length 3.2 m	2 m per stroke	1 m
1 storage pulley	length 4.6 m	2.4 m per stroke	1.9 m
Full capacity	length 7.4 m	4.8 m per stroke	4.5 m

2. Description

2.6 Wire guidance

Guide pulleys are fitted on the wire tension side and on the return side (slack side). The wire is guided to the object being sawn by way of these guide pulleys which can be adjusted in any direction. Wire guides in the form of single- or twin-pair pulley stands, plunge pulleys etc., are mounted at the start and end of the cut. The wire is thus guided and cuts a controlled arc. The wire guides, pulleys and supporting steel tube prevent the wire jumping off uncontrollably at the end of the cut and act as a safety device or as a wire trap in the event of the wire breaking.

Optimum wire guidance is one of the most important and demanding tasks in wire sawing. The distribution of the cut and the arrangement of the pulley stands control the length and curvature of the arc cut by the wire, thus influencing both the service life of the wire as well as the rate of cutting progress.

2.7 Safety concept for the working area

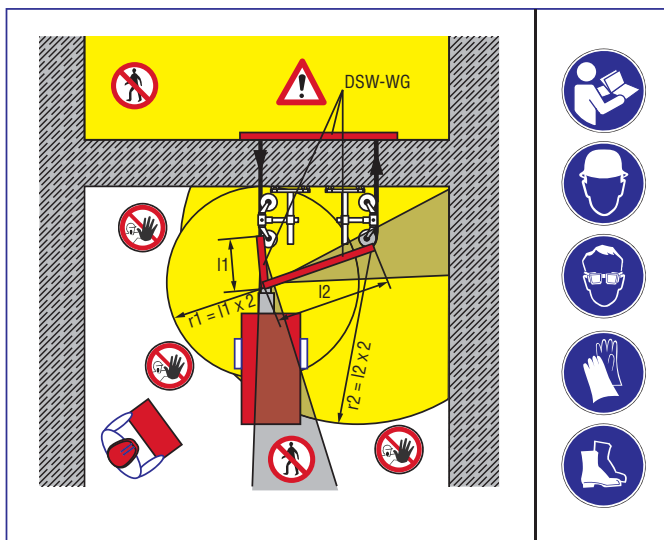

Tools and accessories		
	3.1 Diamond wires	14
	3.2 Accessories for connecting wires	14
	3.3 Accessories for securing the drive unit and wire guides	15
	3.4 DS-WSRW release pulley	16
	3.5 DS-WSPW plunge pulley	16
	3.6 DS-WSVC vertical sawing device	16
	3.7 DSW-WG wire guard	16

3. Tools and accessories

3.1 Diamond wires



IMPORTANT

- Only rubber or plastic coated diamond wires with springs between the diamond beads may be used with the DS WS 15 electric wire saw. The wire must be guaranteed by the manufacturer to be suitable for cutting at a speed of at least 30 m/s and it must fit in the grooves in the guide pulleys.
- Coupling together lengths of wire of different diameters and the use of wires that are not round, wires with loose cutting beads or wires with damaged cores is not permissible.

- Connection of the wire itself and the repair of broken wires must be carried out in accordance with the instructions provided by the supplier of the wire.
- Hilti diamond wires of the standard 11 mm diameter are available in fixed lengths of 10 m, 14 m, 18 m, 22 m, 26 m and 30 m (other lengths and other diameters on request). They are supplied with factory-fitted quick-release connectors. Various wire lengths can be joined together, but only if the diamond beads are of the same diameter.
- Diamond wires with a diameter of 9 mm can be used in conjunction with the pulleys for the standard 11 mm diameter. Wires of less than 8 mm diameter or greater than 13 mm diameter require pulleys with other groove widths or depths.
- If diamond wires without factory-fitted connectors are used, the connectors must be fitted in accordance with the manufacturer's instructions.

Hilti DS-W 11 diamond wire – recommendations for use

Designation Type Specification	Material to be cut Reinforced concrete	Colour code	Diamond wire dimensions		Wire dia. 5.0 mm No. of beads / m
			Bead dia. mm	Diamond facing mm	
DS-W 11 BC	Universal, fast cutting	Yellow	11	1.5	40
DS-W 11 LC	Long life	Black	11	1.5	40
DS-W 11 M	Masonry, abrasive materials	Violet	11	1.5	40

3.2 Accessories for connecting wires

The durability of the wire connection and its efficiency when sawing depends essentially on use of the optimum wire connectors and ensuring that they are fitted correctly.

Correct connection of the wire is an important factor with respect to SAFETY when wire sawing. Hilti recommends the following accessories for the connection of wires. The assembly instructions for Hilti wire connectors are enclosed in the packaging.

Accessories for Hilti diamond wires

Description	Comments / uses	Package contents	Ordering designation
Crimping pliers	for crimping connectors / sleeves	1	DS-WSTHY
Connector	quick-release type	1	DS-WCMV
Pin	replacement pin for connectors	10	DS-WP
Sleeve	repair sleeve	5	DS-WS
O-ring	fitted between coupling / bead	10	O-Ring 10/4.7×2.5
Crimping jaws	replacement jaws for crimping pliers	2	DS-WJ
Cutter	for cutting diamond wire	1	DC125-S

3.3 Accessories for securing the drive unit and wire guides

DS WS 15 wire saw tool set

Ordering designation	Quantity	Use
DS WS 15 tool set comprising:		Wire saws
Hilti plastic toolbox	1	Operator
Accessories, list of contents and uses	1	Operator
Wire sawing applications	1	Operator
Wire sawing video, PAL VHS	1	Operator
Open-end / ring wrench, 19 mm	1	Fastening pulley stand
Open-end / ring wrench, 18 mm	1	Fastening pulley stand
Hammer, 1½ kg	1	Setting anchors, assembly
Screwdriver, 6 mm	1	Clamping spindle
BB blow-out pump	① 1	Blowing out anchor holes
Folding rule, 2-metre	1	Operator
Spirit level	1	Operator
Wooden pencil	2	Operator
Cleaning cloth	1	Operator
Hilti spray	1	Operator
Hilti grease dispenser	1	Operator
Flat brush	1	Operator
Clamping spindle, short, M12S	② 3	Pulley stand, drive unit
DD-CN-SML clamping nut	③ 3	Pulley stand, drive unit
HSD-G M12 setting tool	④ 1	Fastening anchors
Water connection nipple	⑨ 1	Water supply
GK seal	5	Water seal for 356700/5
Steel wedge	⑤ 6	Securing concrete blocks

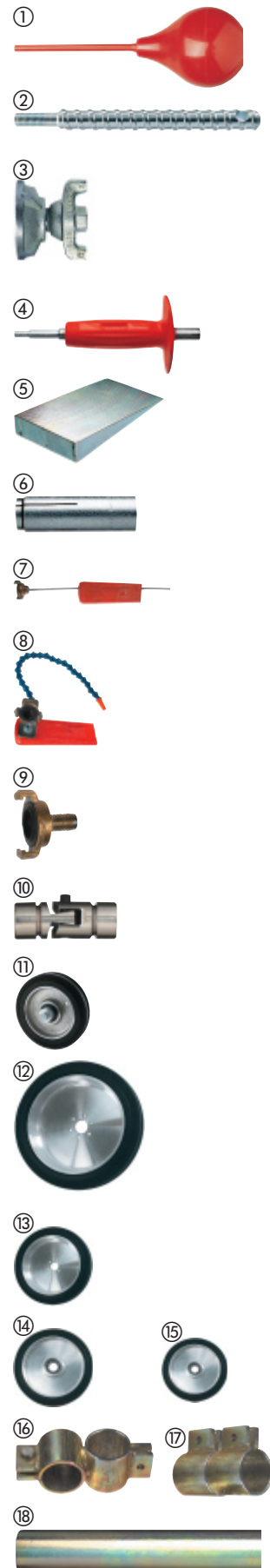

Accessories and wearing parts for Hilti wire saw systems

Ordering designation	Quantity	Use
M12L clamping spindle, long	② 1	Fastening pulley stand, drive unit
HKD-D M12×50 flush anchor	⑥ 50	Hole diameter 16 mm
Water supply, long	⑦ 1	Water supply line
Water supply, flexible	⑧ 1	Water supply line
DS-WSW 200 guide pulley	⑪ 1	Pulley stands, WS 15/WSS 30 drive
DS-WSW 140 guide pulley	1	Plunge saw return pulley
DS-WSW 500 drive wheel	⑫ 1	DS-WSS 30 drive unit
DS-WSWD 280 drive wheel	⑬ 1	DS WS 15 drive unit
DS-WSWS 280 storage pulley	⑭ 1	DS WS 15 drive unit
DS-WSWS 200 storage pulley	⑮ 1	DS WS 15 drive unit
Cross-type tube clamp	⑯ 1	Mounting guide pulleys
Double tube clamp	⑰ 1	Tube extension
Tube, 2"×1 m (60.3 mm outside dia.)	⑱ 1	Tube extension
CEE 32A coupling (female)	1	For extension cable
Round fuse, 3.15 A, 250 V, fast-acting	10	DS WS 15 control unit
Round fuse, 0.63 A, slow-acting	10	DS WS 15 control unit
Fuse, 250 V, 40 A	5	DS WS 15 control unit
DS-WSTHY crimping pliers	1	Crimping connectors and sleeves
DS-WCMV connector	⑩ 1	Quick-release type
WS-WP pin	10	Spare pin for quick-release connector
DS-WS sleeve	5	Repair sleeve
O-ring, 10/4,7×2,5	10	Fitted between connector / bead
DS-WJ clamping jaws	2	Spare jaws for crimping pliers

3. Tools and accessories

3.4 DS-WSRW release pulley Item no. 315834

Used in many applications for cutting through very thick walls or where long cuts have to be made. The release pulley ensures optimum wire contact length and thus a high cutting speed.

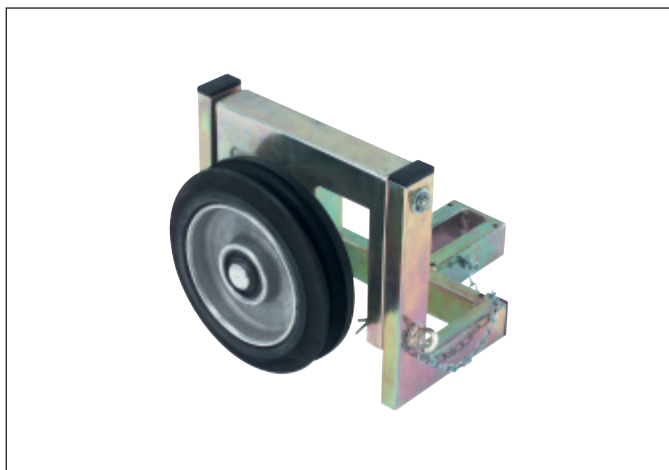

3.6 DS-WSVC vertical sawing device Item no. 339312

For simple, fast cuts directly below the wire drive unit. No further pulleys or wire guidance system is then used (no single-pair pulley stand). The optimum solution for applications where the drive normally stands in a horizontal position. For sawing ceiling sections, supporting beams etc.

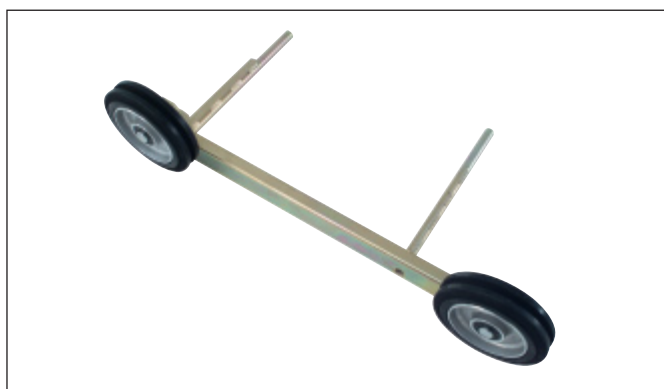

3.5 DS-WSPW plunge pulley Item no. 365428 / 247620

For plunge applications of all kinds. At least 2 pulleys are required. Can also be mounted on the single-pair pulley stand if necessary.



3.7 DSW-WG wire guard Item no. 365426

Wire guards must be fitted in situations where it cannot be ensured that persons do not enter the danger area while the equipment is in operation, i.e. the area in which flying fragments etc. present a risk of injury, or in situations where there is a risk of damage to property or other equipment within this area.

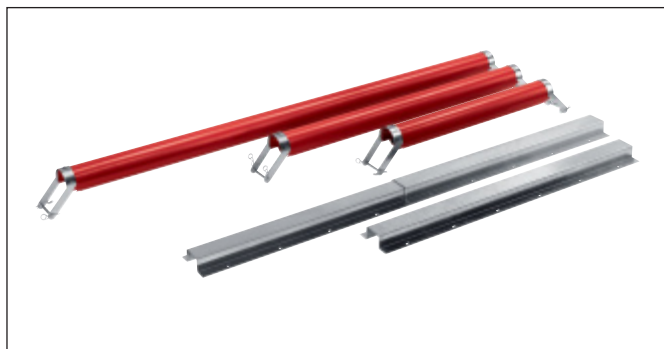

Technical data	4.1 Power supply	18
	4.2 Dimensions and weights	18
	4.3 Insulation class	19
	4.4 Climatic conditions for operation and storage	19
	4.5 Technical data	19
	4.6 Noise values	20
	4.7 Rating plates	20

4. Technical data

4.1 Power supply

Electric supply

Mains supply voltage:	400 V, 3-phase, 50/60 Hz
Fuse rating:	At least 16 amps, 32 amps recommended.
Generator:	Use only generators with an output of at least 40 kVA. The generator must be earthed when in operation.

Water supply for drive and wire cooling

Cooling water:	min. 5 l/min at max. 6 bar
----------------	----------------------------

Compressed air for the drive (compressor)

Min. 6 bar and 100 l/min. for the drive pneumatic advance

4.2 Dimensions and weights

Drive

Dimensions	1560×790×920 mm
Weight	approx. 266 kg

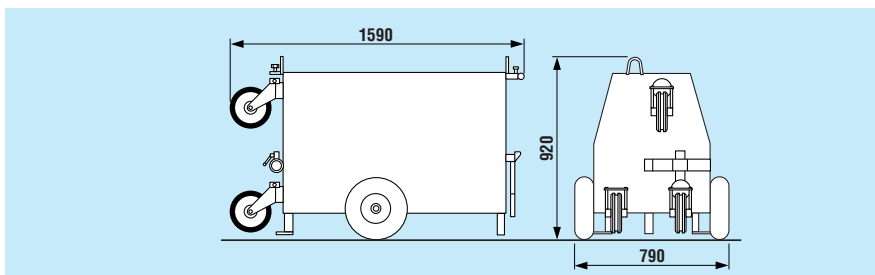

Control unit

Dimensions	520×590×1080 mm
Weight	approx. 68 kg

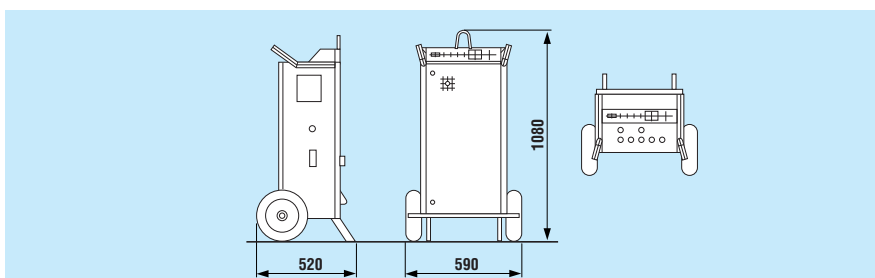

Single-pair pulley stand

Dimensions	460×240×560 mm
Weight	approx. 23 kg

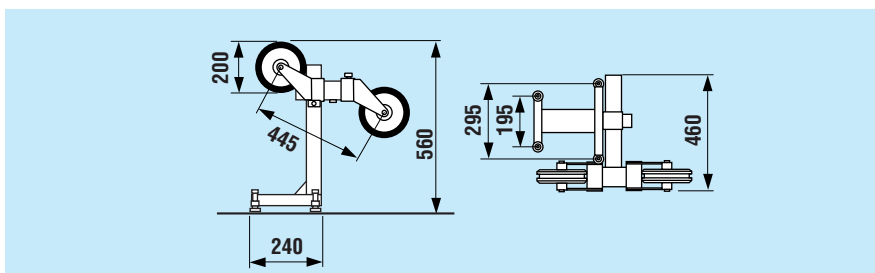

Compressor

The compressor supplied by Hilti with the equipment or any other compressor that complies with the specified technical data may be used.

4.3 Insulation class

Drive:	protection against water jets (use of high-pressure cleaning systems is not permissible)
Control unit:	protection against water spray (use of high-pressure cleaning systems is not permissible)

4.4 Climatic conditions for operation and storage

- The data specified for the DS WS 15 wire saw is guaranteed up to a height of 2000 m above sea level.
- Likewise, the data specified is guaranteed for ambient temperatures within the -15°C to $+40^{\circ}\text{C}$ range (at temperatures below zero with the equipment warmed up before use).
- When dry, the equipment may be stored at temperatures between -20°C and $+55^{\circ}\text{C}$.

4.5 Technical data

DS WS 15 drive unit (supplied and controlled by the DS WS 15 control unit)

Drive wheels	2 × 280 mm dia.
Rated output P1	2 × 7.5 KW continuous output (= 15 kW drive output)
Wire speed	Infinitely variable 0 – 27 m/s
Wire storage in the drive	Maximum 9.2 m (length of wire min. 3.2 m – max. 12.4 m)
Drive unit dimensions	1560 × 790 × 920 mm
Drive unit weight	Approx. 266 kg
Electrical protection class	IP 65
Cable length (system cables)	7 m
Cooling system for two 7.5 kW electric motors	Water cooling system: min. 5 l/min at max. 6 bar

DS WS 15 control unit

Rated voltage	400 V ~ 50/60Hz 3P+N+PE or 3P+PE (alternating current)
Rated current	25 amps
Fuse rating	32 amps
Min. fuse rating	16 amps
Mains electrical connection	400 V plug CEE 32 (5-pole)
Ground fault circuit breaker (PRCD)	30 mA in mains supply on site
Control voltage	24 V (DC)
Control unit dimensions	520 × 590 × 1080 mm
Control unit weight	Approx. 68 kg
Electrical protection class	IP 54
Generator output	Min. 40 kVA

4. Technical data

Compressor

Compressed air	Min. 6 bar
Air volume	Min. 100 l/min
Supply connection	230 V





4.6 Noise values





Equipment: DS WS 15 electric wire saw

Sound pressure level as per
DIN EN ISO 3744 * < 79 dB(A)

* Measured at a distance of 2.8 m from the drive unit

4.7 Rating plates for drive unit and control unit

HILTI		DS EB WS15 03			
		Made in Austria			
CONTROL UNIT					
Serial number		0000000			
Prim.in	400 V	3P+N+PE	50/60Hz	32A	17kW
Sec.out	360Veff.	5-67 Hz	IP54		
   					
FFE		ETL	DATE		
356648		08	10		

HILTI		DS WS15 03	
<small>HILTI = trademark of HILTI Corp. Schaan/LI</small>		<small>Made in Austria</small>	
DRIVE UNIT			
Serial number		0000000	
$n_0 = 140-1900$ rpm	2 - 27 m/sec	IP 65	
   			
FFE		ETL	DATE
356648		08	10

Safety precautions		
	5.1 Safety measures at the working area	22
	5.2 Preparations	22
	5.3 Securing the objects being cut and disposal of sawing slurry	22
	5.4 Use of the equipment as directed, operating safety	23
	5.5 Electrical safety	24
	5.6 Safety precautions during transport	24
	5.7 General safety information	25

5. Safety precautions

5.1 Safety measures at the working area

- Safety measures must be implemented in the area where sawing is taking place so that operators and third parties cannot be injured or property damaged by debris or objects which may fly off during the sawing operation (small stones, pieces of wire, sawing slurry, etc.). Safety measures must also be implemented in the area not directly visible to the operator, behind where sawing is taking place.
- Persons must NEVER enter the hazardous area while sawing is in progress. The hazardous area extends to at least twice the radius of the length of wire that would be unleashed in the event of the wire breaking and also includes the area in the extended axis of the wire tension side. The operator is responsible for cordoning off the area and restricting access. The hazardous area may be entered only when the EMERGENCY STOP button is in the pressed-in position.

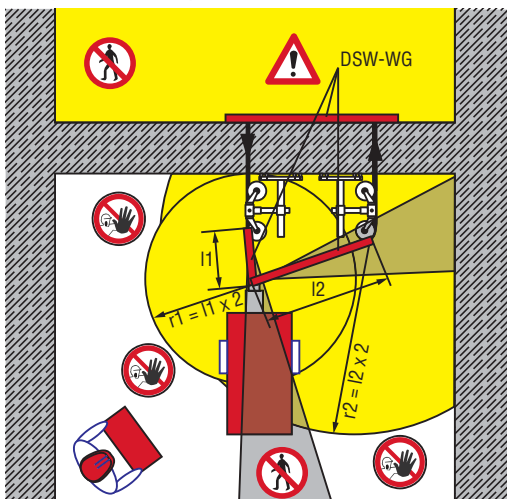

Approval must be obtained from the site engineer or architect prior to carrying out drilling and sawing work.

- Make sure that no gas, water, electricity or other supply lines are located in the cutting area. Supply lines located close to the cutting area which could be damaged by falling parts, for instance, must be specially protected and, if necessary, temporarily switched off etc.
- Ensure that the cooling water used is drained or extracted in a suitably controlled manner. Water that is allowed to drain away or spray around in an uncontrolled manner can lead to damage or accidents. The fact that water could drain away into internal, hidden cavities, e.g. in brickwork or masonry, must also be taken into account.
- Make a careful note of any influence the immediate surroundings may have on operations. Do not use the wire saw in areas where there is a risk of explosion or in close proximity to combustible materials, fluids or gases. Flying sparks or electrostatic discharge can lead to fires or explosions.
- Do not cut materials in which the cutting process may produce toxic or explosive dust or vapours.
- Do not cut easily combustible aluminium or magnesium alloys.



5.3 Securing the objects being cut and disposal of sawing slurry

- Steel wedges and/or supports must be used to prevent uncontrolled movement of parts that are being cut free in order to avoid injuries and to prevent the diamond wire becoming trapped or jammed.
- Make sure that sections of the structure that are cut free (concrete blocks etc.) do not endanger the working area and the operating personnel. The part of the structure to be cut free, e.g. a concrete block that is to be sawn from a ceiling, must be supported to prevent it falling.
- Use only approved and appropriately dimensioned means of securing and lifting for the removal and transportation of parts that have been cut free. Such parts may have a weight of many tons.
- Never loiter in the vicinity of loads suspended by cranes.
- The area of the cut or the opening created by the cut-



- Always keep the free wire lengths between the drive unit and object being cut as short as possible. NEVER operate the equipment without mounting the wire guides on the construction component to be sawn or, respectively, at the saw kerf. In the event of wire breakage, the wire is automatically retained in the hollow axle of the guide pulley, thus reducing the danger of wire whiplash. Long, free wire lengths can lead to dangerous wire whiplash in the event of wire breakage.



5.2 Preparations

- Sawing work influences the statics of the structure.

ting process must be safely and visibly cordoned off in order to avoid the possibility of persons falling.

■ Introducing sawing slurry into the drains or sewage system without suitable pre-treatment is problematic from an environmental point of view. Ask the local authority responsible about existing regulations. We recommend the following pre-treatment:

- Collect the sawing slurry (e.g. using an industrial vacuum cleaner)
- Allow the slurry to settle and dispose of the solid portion of the waste at a building waste disposal location (the separation process can be accelerated by adding a flocculent).
- Neutralise the residual water by adding a neutralising agent or dilute it by adding a large quantity of water before allowing it to enter the drainage system.

5.4 Use of the equipment as directed, operating safety

■ The DS WS 15 wire saw has been developed for the technical demolition of steel, concrete, stone or brickwork structures in construction and civil engineering applications. It can be used for wet or dry sawing (the wet sawing technique is normally used). Use extending beyond this is considered to be not as directed and requires to be clarified in advance with the manufacturer.

■ The operator in charge must be aware of the possible dangers and of his responsibility for safety, both with regard to himself and to others.

■ The wire saw may be operated only by specialists trained in concrete cutting techniques, referred to in the following as “operators”. These persons must be familiar with the content of these operating instructions and must have been trained in their safe application by a Hilti specialist.

■ Check that the wire saw and its components, the sawing wire and wire connectors and all accessories are in good condition and perfect working order before use. Rectify any damage before sawing commences.

■ Position the control unit as far as possible outside the danger zone and remain in the vicinity of the control unit during cutting operations.

■ **The drive unit must stand on a solid, level surface. If positioned on scaffolding, the scaffolding must be correspondingly stable and the drive unit must be**

secured to prevent it moving or falling. Serious damage or injury can result if the drive unit is allowed to fall or crash down.



■ Connect the equipment to the electric power supply only after the wire saw has been fully set up.

■ The protective cover must always be fitted on the drive unit when the saw is in operation.

■ Persons may enter the danger zone (e.g. to adjust pulleys or water supply nozzles) only after the drive has been switched off and when the drive pulley has come to a standstill. Switch off or disconnect the electric supply before entering the danger area.

■ Observe the recommended guide values for cutting speed and advance pressure when sawing.

■ Use only rubber or plastic coated diamond wires approved for use at a speed of at least 30 m/sec.

■ For safety reasons, always keep the free wire length as short as possible. This reduces the risk of wire whiplash in the event of wire breakage.

■ Do not hold anything against the moving diamond wire by hand, e.g. with a view to using it as an improvised saw.

■ Wire breakages can be reduced considerably by using high-quality diamond wires and wire connectors (in conjunction with the appropriate tool for fitting the connectors).

■ **An appropriately long wire must be used when dry sawing, e.g. in masonry. This permits the wire to cool down during its travel prior to coming into contact with the workpiece on the next revolution.**



■ **The wire may become hot, do not touch it without gloves!**



■ **Dry sawing may create a great deal of dust, in which case respiratory protection should be worn.**

5. Safety precautions

■ National regulations and laws, as well as the operating instructions and the safety information applicable to the accessories employed (sawing wire, fastening accessories etc.) must be observed.

■ Use only adequately dimensioned fastening components (anchors, bolts etc.) to secure the pulley stands and the drive unit. Recommendations can be found in the wire saw brochure.

■ Use only the accessories recommended in these operating instructions. See Section 3. The use of other accessories may result in damage or injury.

■ When using ladders, e.g. when mounting the single-pair pulley stands on walls, ensure that the ladder conforms to regulations, is undamaged and stands securely on the floor.

■ The operator must ensure that no person is present in the danger zone at any time during operation of the saw. This also applies to areas not directly visible, e.g. to the rear of the section of the structure being sawn. If necessary, a sufficiently large area must be cordoned off or security personnel posted accordingly.

■ Stay alert and carefully monitor the sawing operation, the cooling water system and the area surrounding the workplace. **Do not operate the wire saw if your full concentration is not on the job!**

■ Use of the wire saw for any purpose other than as described is not permissible, e.g. it may not be used as a means of transportation or as an elevator.

■ No modifications may be made to the wire saw, especially to the drive and/or control unit.



5.5 Electrical safety

■ Always check the wire saw before operation. In particular, check that the electric cables, plugs and hoses are in good condition. Do not operate the equipment if it is damaged in any way, if the equipment is not complete or if the operating controls or components do not function as they should. In case of faults or malfunctions, the wire saw should be repaired by an authorised Hilti repair mechanic or qualified electrical specialist.

■ Connect the wire saw only to a power source that is equipped with an earth conductor and ground fault cir-

cuit breaker (PRCD). Check that these items are in perfect working order before operating the equipment.

■ Make sure that the mains voltage corresponds to the specification given on the rating plate.

■ Protect yourself against electric shock, i.e. avoid contact with earthed components such as pipes, radiators and the like.

■ Keep all electric cables, especially their plug connections, in a dry condition. Close the electric sockets by means of the covers supplied when not in use.

■ Always pull on the plug itself, never on the cable, when disconnecting the cable from the control unit or distribution unit. Do not permit electric cables to become trapped or squashed and protect them from sharp edges, heat and oil.

■ Use of extension cables : Use only extension cables with adequate conductor cross-section which are approved for the intended field of use. Do not work with extension cables when they are rolled up. This can result in a drop in output at the equipment and may cause the cable to overheat. Replace damaged extension cables.

■ Disconnect the power cable before opening the doors of the control unit.

■ Disconnect the power cable before beginning cleaning and maintenance work or in the event of a lengthy interruption between periods of operation.

■ Should you find that power consumption increases when the drive motors are idling, or notice a loss in performance during normal saw operation, then one of the three fuses may have blown. Switch off the drive unit and the main switch, open the control unit doors with the key and check / replace the safety fuses (please also refer to the “Troubleshooting” section).



5.6 Safety precautions during transport

■ Make sure that the wire saw cannot move about during transportation.

■ Always avoid adopting a bent-over body position when carrying heavy items, i.e. keep your back straight when lifting and carrying.

■ Use the handles provided for transportation of the

drive unit and control unit. Ensure that the handles are always kept clean and free of grease.

- If the drive unit and control unit are to be transported by means of a crane, the lifting points provided must be used.
- Because of the risk of tipping, the drive unit may be transported in an upright position only when assisted by at least two persons and this may be done only on a solid floor or solid ground.



5.7 General safety information

- Use the electric wire saw only when you have read the operating instructions, when you are familiar with the information contained therein and when you have been trained to use the equipment safely by a Hilti specialist. All warnings and safety information must be observed.
- Always keep the operating instructions with the equipment and pass them on to any subsequent user who has been trained in its use.
- When not in use, store the wire saw in a locked, dry place out of reach of children.
- In addition to carrying out the specified care and maintenance, careful cleaning is also a prerequisite for safe, trouble-free operation of the equipment.
- Do not leave tools (e.g. open-end wrenches) in place on the equipment. Check the drive unit to ensure that all tools have been removed before switching on.
- Keep the working area tidy and well lit. An untidy workplace and inadequate lighting increases the risk of accident.



- Wear suitable, close-fitting work clothes including a hard-hat, protective goggles, protective gloves and safety footwear.



- Respiratory protection should be worn when work-

ing in enclosed or poorly ventilated areas and when dry cutting is being carried out.

- Keep children and other persons well away from the workplace and allow no-one to touch the wire saw or power cable.
- **Failure to comply with the warnings and safety information may lead to severe or possibly fatal injury as well as serious damage to the equipment and other property.**
- **The machine is not intended for use by children, by debilitated persons or those who have received no instruction or training.**
- **Children must be instructed not to play with the machine.**

■ Dust from material such as paint containing lead, some wood species, minerals and metal may be harmful. Contact with or inhalation of the dust may cause allergic reactions and/or respiratory diseases to the operator or bystanders.

Certain kinds of dust are classified as carcinogenic such as oak and beech dust especially in conjunction with additives for wood conditioning (chromate, wood preservative). Material containing asbestos may be worked on only by specialists.

Where the use of a dust extraction device is possible it shall be used. To achieve a high level of dust collection, use a suitable vacuum cleaner of the type recommended by Hilti for wood dust and/or mineral dust together with this tool. Ensure that the workplace is well ventilated. The use of a dust mask of filter class P2 is recommended. Observe current national regulations applicable to the materials to be worked on.



6. Preparing the saw system for use

Preparing the saw system for use	6.1 Planning the wire guidance system	28
	6.1.1 Positioning the wire guide pulleys	28
	6.1.2 Wire pressure	28
	6.2 Drilling through holes for the wire	28
	6.3 Setting up the electric supply	28
	6.4. Transporting the wire saw	29
	6.5 Securing the wire guides and saw drive unit	30
	6.6. Connecting the electric power, water and compressed air	30
	6.7. Rigging and tensioning the wire	31
	6.8. Setting up the wire cooling system	34
	6.9. Basic applications	34
	6.9.1 Standard vertical cut	34
	6.9.2 Vertical cut with release pulley	34
	6.9.3 Distance between the drive and object being cut	35
	6.9.4 Optimum length of cut	35
	6.9.5 Standard horizontal cut	35
	6.9.6 Flush horizontal cut	36
	6.9.7 Using plunge pulleys	36
	6.9.8 Using the vertical cutting device	37
	6.9.9 Wire guard assembly instructions	37

6. Preparing the saw system for use

6.1 Planning the wire guidance system

■ Before installing the wire saw, you must carefully study the situation and plan the wire guides, the drilling of through-holes, the sequence of the work and the procedure involved. You must also plan the cooling water supply and, if necessary, waste water disposal.

■ Consideration must be given to safety aspects and cordoning off to prevent access by third parties etc.

■ Secure the area, plan the removal and transportation of the sawn-out sections of the structure and all other necessary measures.

6.1.1 Positioning the wire guide pulleys

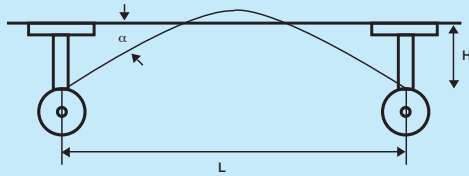

Rule of thumb : Pulley clearance $H = 0.2 \text{ m}$ per metre sawing length L

□ Sawing length L : ● 1 metre ■ 2 metre ▲ 3 metre ↗ 4 metre

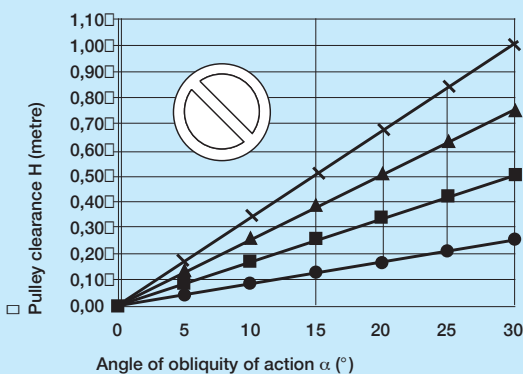

6.1.2 Wire pressure

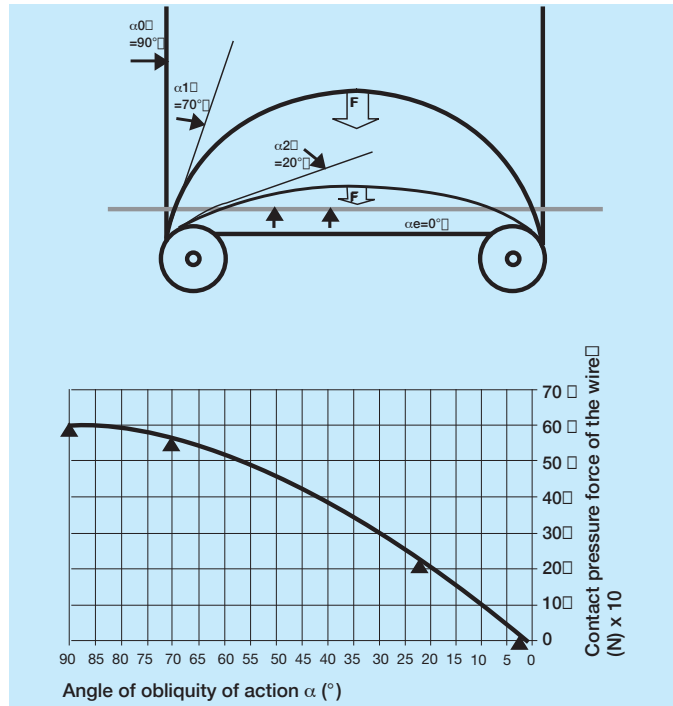

6.2 Drilling through-holes for the wire

■ According to the situation, the material to be cut and the amount of reinforcement in the concrete, a hammer drill and long masonry drill bits or a diamond coring machine mounted on a stand can be used to drill through-holes. Depending on the thickness of the section to be cut and the material involved, we recommend drill bits of 16 mm, 37 mm, 67 mm or 102 mm diameter.

■ Depending on the application, you will also require accessories and special solutions for drilling to greater depths.

6.3 Setting up the electric supply

NOTE

■ The DS WS 15 wire saw will run even when the electric supply has only 4 conductors (1 earth/ground and 3 phases). However, the two 230 V supply sockets on the control unit will provide no power if the neutral conductor is missing. In this case it will be necessary to use a separate 230 V supply cord for the compressor, lights or a rotary hammer drill etc.

■ Ensure that the electric power supply has a fuse rating of at least 16 amps. A fuse rating of 32 amps is ideal. The jobsite power connection must be earthed/grounded and equipped with a 30 mA ground fault circuit breaker (PRCD). The earth connection and ground fault circuit breaker must be tested before the saw is operated.

6. Preparing the saw system for use



■ The 5-pole, 400V socket on the control unit may not be changed or replaced by another type. If necessary, equip your electric extension cable with the EURO socket (400V, 32 amp, 5-pole) supplied.

■ Cable cross-section and maximum cable lengths

Current	F mm ²	F mm ²	F mm ²	F mm ²	F mm ²
Amps	2,5	4	6	10	16
16	49 m	78 m	117 m	195 m	Not recommended
25	39 m	63 m	94 m	156 m	250 m
32	24 m	39 m	59 m	98 m	156 m

Example: At an average current consumption of 25 amps and with a conductor cross-sectional area of 4 mm², the wire saw may be positioned at a maximum distance of 63 m from the power distribution point.

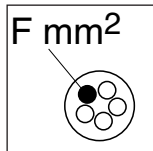

Cable connection code for 400 V 32 A Euro plug (male) at the control unit:

PE = earth / ground

N = neutral

L1 = phase

L2 = phase

L3 = phase

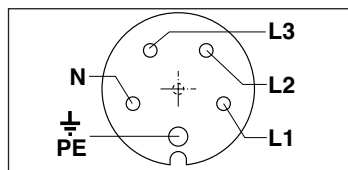

■ The maximum load that may be carried by the two 230 V sockets is:

Max. 800 W at both sockets (2 × 800 W), or

Max. 1600 W at one socket (1 × 1600 W)

6.4 Transporting the wire saw

■ The wheels on the DS WS 15 drive unit must be folded up before it is transported in your vehicle or on a trailer. The drive unit, control unit and other components must be secured with suitable belts to prevent them moving around or falling over.

■ Use suitable lifting gear or non-slip, stable ramps to load / unload the equipment into the vehicle or onto the trailer.

■ The DS WS 15 control unit can be moved without any problem by means of the 2 hand grips. A load may be applied to the folding surface to the rear of the control unit. A lifting point is provided for the purpose of transportation by crane.

■ The DS WS 15 drive unit can be easily moved on sol-

id ground on its transportation wheels (located in line with the centre of gravity) by means of the pull-out T-bar located at the rear. The wheels can be brought from the standing position to the transport position (and vice versa) by one person without any trouble by means of a lever, whereupon they can then be locked in position (see fig. **1**, **2**). Two lifting points are fitted for transportation by crane.



6. Preparing the saw system for use

6.5 Securing the wire guides and saw drive unit

■ A basic prerequisite for efficient and safe wire sawing is ensuring that the equipment is securely and safely fastened in position.

■ Fastening components suitable for the material in question must be used to secure the drive unit and for mounting the single-pair pulley stands, release pulley stand etc.

■ Tension rods located in through-holes, for example, may also be used in masonry.

WARNING

Use an anchor suitable for the material on which you are working and observe the anchor manufacturer's instructions.

NOTE

Hilti M12 metal expansion anchors are usually suitable for fastening diamond core drilling equipment to uncracked concrete. Under certain conditions it may be necessary to use an alternative fastening method. Please contact Hilti Technical Service if you have any questions about secure fastening.

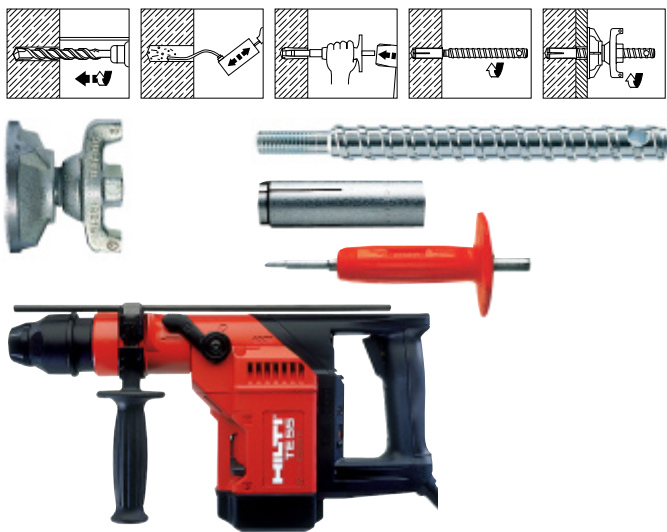

■ The clamping spindles and clamping nuts with swivelling baseplate recommended for use with these anchors ensure that the equipment can be fastened in position quickly and securely. Important: The clamping spindles are wearing parts and should be replaced when necessary. Check that they are in good condition before use and do not straighten them by hammering.

■ Alternatively, ceiling support jacks, quick-release columns or tension belts may be used instead of anchors for securing the DS WS 15 drive unit.

■ Depending on the floor or ground on which the DS WS 15 drive unit is standing, it may not always be

necessary to secure the unit. If the floor has a rough surface, or the ground is soft, the weight of the drive unit itself is sufficient to achieve the reaction force necessary to oppose wire tension during sawing.

■ The anchors for fastening the single-pair pulley stands do not require to be very precisely positioned. Thanks to their adaptable clamping system, the pulley stands and guide pulleys can always be lined up precisely with the cut. Approximate positioning is adequate (see fig. 3).

■ In addition to the central clamping spindle, the levelling screws on the pulley stands can also be tightened. The wire guide pulleys are then fastened securely and will not work loose, even when subjected to vibration.

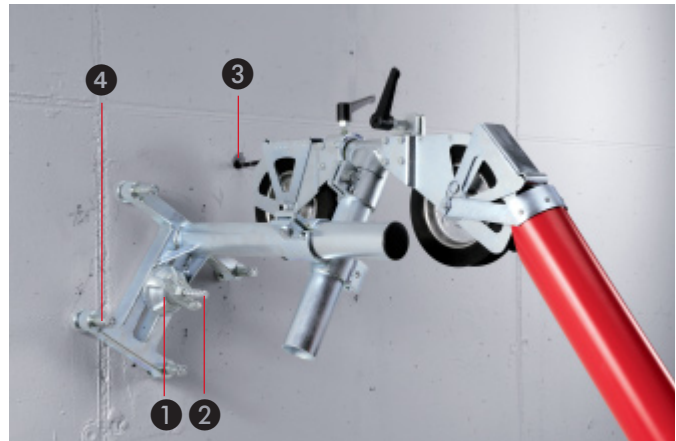

- 1 Clamping nut with swivelling baseplate
- 2 Clamping spindle with double-start thread
- 3 Through-hole for the diamond wire
- 4 Levelling screw

6.6 Connecting the electric power, water and compressed air

Please also refer to Section 2, "Description of the saw system"

■ **Situation: The wire saw is installed, all switches at the control unit are in the OFF or NEUTRAL positions, the EMERGENCY STOP button is pressed in.**

■ Connect the system's own 400 V power cable and 24 V control cable between the drive and the control unit. **Important:** The control unit must be positioned outside the hazardous area of wire saw operation!

■ Connect the socket of the 400 V mains supply cable / extension cable to the control unit (EURO plug, 400 V, 32 A, 5-pole).

6. Preparing the saw system for use

■ Install the water supply with a feed of at least 5 lt. / min at a max. water pressure of 6 bar for the DS WS 15 drive, and connect it to the rear of the drive unit by way of the quick-release couplings.

■ Lead 2 cooling water hoses from the front of the drive unit (close to the guide pulleys), by way of the quick-release water couplings, to the cutting face where sawing is taking place and connect them to the flexible water supply nozzle and to the long water supply nozzle.

■ Turn the main switch at the control unit to ON. The indicator lamp lights up green and the outflow water valve at the drive unit closes automatically. **Note:** The red ERROR warning lamp may possibly light up for approximately 6 seconds, until the correct tension is reached.

■ Connect the compressor to the 230 V socket at the control unit and switch it on immediately. As soon as the compressor switches off automatically, i.e. when the pressure tank is full, connect the compressed air hose of the compressor and the control unit (one hose), and then connect the control unit to the drive by means of the 2 long compressed air hoses. The compressor restarts automatically, when necessary.

■ Open the tap at the jobsite water supply. The water does not yet flow through the machine to the water nozzles (water flows only when the cooling water is switched on at the control unit).

■ The DS WS 15 drive unit has to be cooled even when used for dry cutting applications (the diamond wire may not have to be cooled when cutting brickwork). In environments where temperatures are normal, as an alternative to connection to a fresh water supply, cooling can be achieved by means of a submersible pump in a water reservoir of 30–50 litres. The cooling water can be returned to this reservoir from one of the two water taps located at the front of the drive unit, thus forming a closed circuit system.

■ Insufficient cooling water or a water temperature significantly in excess of 20°C can lead to premature activation of the temperature protection control switch. The motors then switch off automatically and the "Error" warning lamp lights (see also "Error messages" section).

6.7 Rigging and tensioning the wire

■ **Situation:** The length of the wire and the optimum position of the drive has been fixed. The drive unit has been set up at approximately the correct distance to the structure to be cut. The wire has been fitted with wire connectors.

■ **Important:** When the wire is threaded through, attention must be paid to correct direction of travel.

The forked piece of the wire connector must correspond to the directional arrow on the wire. Should the arrow on the wire no longer be visible, the direction of travel can be determined from the diamond beads. The beads are slightly conical in the direction of travel (narrow end ahead) and the diamonds can be seen to have a "tail" that trails behind.

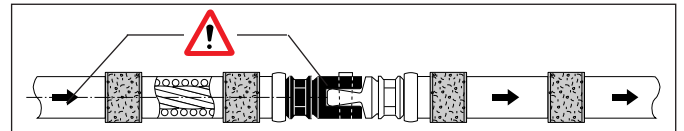

■ The wire running in the direction of tension from the object being cut is always fed to the drive unit via the lower guide pulley or, respectively, through the lower hollow axle. **Important:** Always use the shorter free wire length as the tension side! The system will then work more efficiently, more safely and with reduced wire wear.

■ Feed the wire from the hollow axle of the lower guide pulley of the drive **1** at the tension side through the pulley guide mounted at the closer through-hole **2** and then through the hole to the rear of the object being cut. From there, the wire should return via the next previously-drilled through-hole **3** to the next pulley guide from where it is then fed back to the slack side (wire return side) of the drive unit **4**.

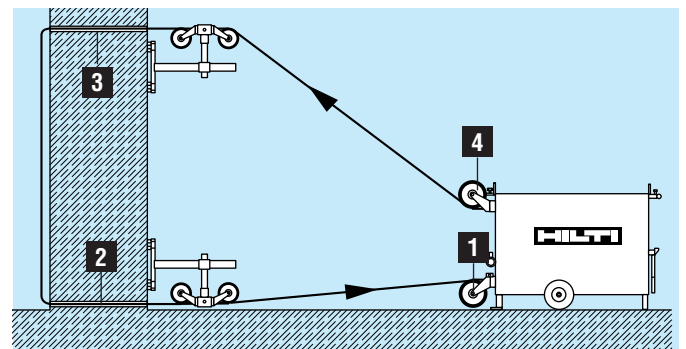

■ **Important:** We recommend that the following procedure is followed now, at the latest, before the two ends of the wire are connected: The operators should pull the wire through by hand, in both directions alternately in a "sawing" motion, so that the wire already begins to cut slightly into the object to be sawn. This procedure ensures that the wire guides are secured correctly in position at the object to be cut and that the wire is free to move when sawing begins.

■ The operator should now twist the wire in a counter-clockwise direction (looking towards the end face of the wire or wire connector), applying about 1–1.5 turns per metre. Finally, the two ends of the wire should be con-

6. Preparing the saw system for use

nected with the pin provided. The vice mounted on the front of the drive unit is designed to hold the wire securely and thus makes this operation easier. Twisting the wire ensures that the wire wears evenly.



■ Move the drive motor on the carriage manually into the desired position. Before this can be done, the two compressed air connections located at the rear of the drive must be connected, or coupled together (so that the air in the pressure cylinders can circulate).



■ Starting from the upper guide pulley (hollow axle) located at the slack side, pass the connected wire around the 280 mm diameter drive wheels (refer to the sticker on drive unit) and fix the lower guide pulley on the ten-

sion side in the corresponding storage position. Pass the wire around the storage pulleys in one or more turns, as necessary. When doing so, it may be necessary to reposition the entire drive unit by moving it forward or back before fastening it in position..



■ Ideally, the drive should be rigged with only the basic minimum length of wire (at least 3.2 m) at the commencement of sawing. This allows the maximum thickness to be sawn through without having to adjust or change the wire. Nevertheless, it is possible to begin sawing with the wire storage pulleys occupied to full capacity.

■ The operator at the control unit should set the advance pressure to approximately 1 bar by adjusting the pressure control and then tension the wire by moving the advance lever (fig. 1). At the same time, the operator at the drive unit should ensure that the wire is lying correctly on the storage pulleys (fig. 2).



6. Preparing the saw system for use



Warning: avoid hand injuries



Wear protective gloves

CAUTION

Never grip the wire close to a pulley.
Your hand could be crushed and injured.

■ Align the lower hollow axle and guide pulley with the corresponding storage pulley (observe the marking grooves) and tighten it in this position (fig. 3).



■ Check the entire course followed by the wire and readjust any lengths of wire which may have jumped off the

guide pulleys. Make sure that the guide pulleys on the pulley stands are aligned with the drive unit. Exact alignment has been achieved when the wire runs in the centre of the guide pulleys.

■ If necessary, e.g. when an extremely soft material is being cut, tighten the compressed air cylinder lock at the cylinder. This prevents the wire from sticking in soft material when the saw is started (fig. 4).



■ Fit the protective cover once the wire is tensioned. Make sure it is secured and engaged correctly. The drive unit can be started only when the protective cover is locked in position (fig. 5).



6. Preparing the saw system for use

6.8 Setting up the wire cooling system

■ Ideally, hoses should be led from the 2 water connections with valves at the front of the control unit to the flexible water supply nozzle at the point where the wire enters the front side of the object being cut and to the second (long) water supply nozzle positioned at the diamond wire on the rear side of the object. The water supply nozzles can be mounted by pushing the wedge into the kerf or temporarily by some other suitable means.



■ When dry cutting, the water outlet from the drive unit is fed into the drainage system or a reservoir and not to the saw kerf.

■ The cooling water supply is controlled by the ON and OFF buttons on the control unit.

■ If less water than required for cooling the drive unit is used for cooling the wire, a proportion of the water can be fed directly into the drainage system by way of the second valve located at the front of the drive unit.



Water connection to drive unit



Water supply to the cut



Control unit – water on / off

6.9 Basic applications

6.9.1 Standard vertical cut

- Illustration: Using a single-pair pulley stand (DS-WS-SPP)
- Optimum length of cut
- Avoid a tight radius in the concrete
- Good cutting performance (cutting speed)
- Normal rate of wire wear

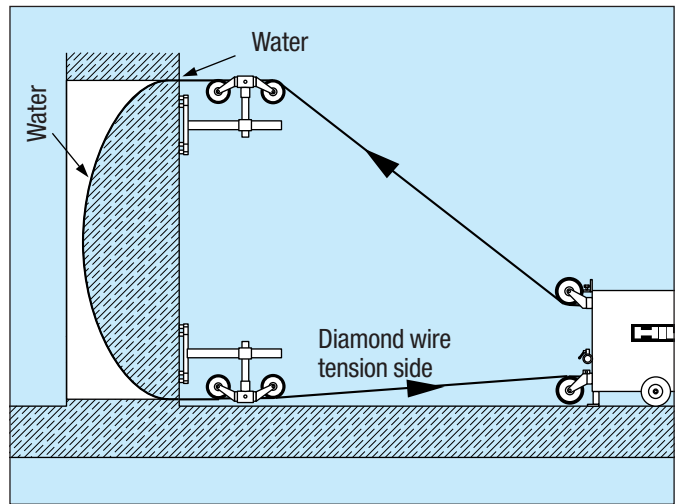

6.9.2 Vertical cut with DS-WSRW release pulley

1st step

- Illustration: Using a double-pair pulley stand (made up from two DS-WS-SPP)
- Relatively short length of cut
- High cutting performance (cutting speed)
- Slightly higher rate of wire wear
- **Note:** Once the kerf reaches the height of the pulley ①, rotate the pulley so that it points downwards.

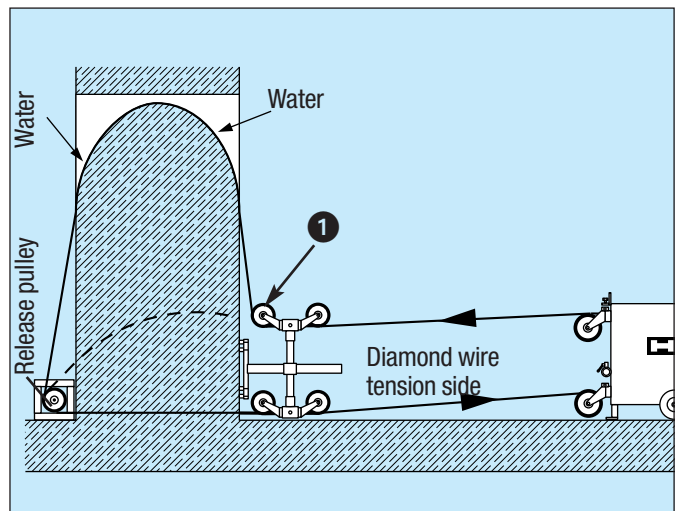

6. Preparing the saw system for use

2nd step

- Disengage the wire from the release pulley when the cut is approx. 50% complete, i.e. the wire then also begins to cut from below.
- Provided the operator remains outside the danger zone, this can be done while sawing continues by means of a long string: simply pull out the bolt from the release pulley!

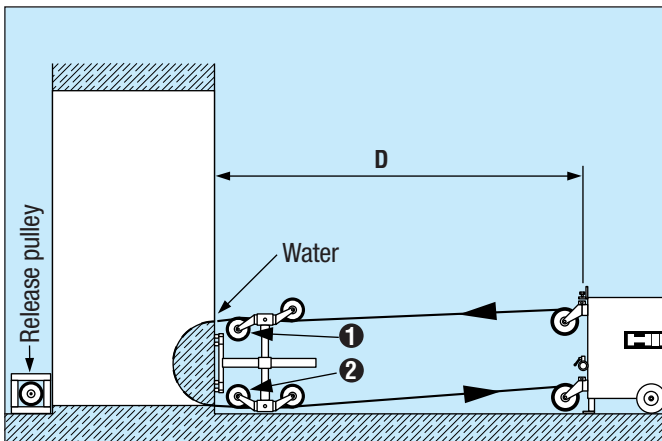

- The wire is caught by pulleys ① and ② when it escapes from the kerf at the end of the cut.

Example: Using a double-pair pulley stand for a vertical cut through a concrete component

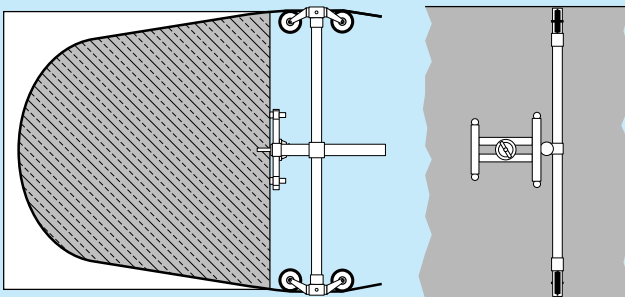

6.9.3 Distance “D” between the drive and object being cut

- The distance “D” between the drive unit and the object being cut is determined by the application. The ideal distance, i.e. the “free wire length”, is approximately 2–3 m, but it can also easily reach 5–10 m. However, for even greater distances, the wire must run over an additional pulley stand. The distance “D” (or “free wire length”) should always be kept as short as possible for safety reasons.

6.9.4 Optimum length of cut “L”

- The optimum length of cut “L”, i.e. the wire length effectively involved in the cutting process, ranges from approximately 2 to 8 m for the DS WS 15 wire saw. This enables the operator to achieve the greatest efficiency, and also ensures good service life of the wire.

6.9.5 Standard horizontal cut

- Position the drive unit at a short distance from the object to be cut, with the tension side facing the object.

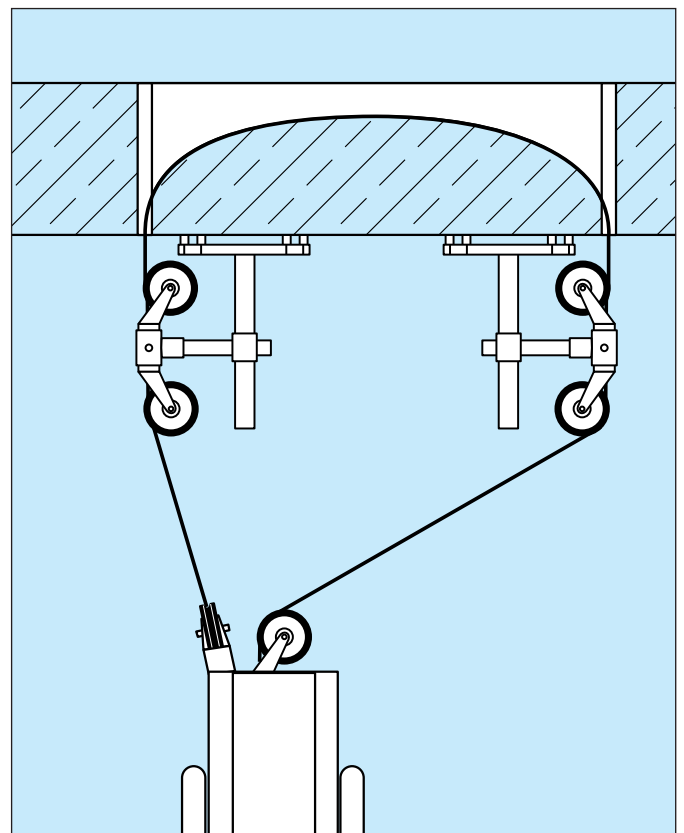

6. Preparing the saw system for use

6.9.6 Flush horizontal cut

■ The pulley stand should be mounted so that the pivoting guide pulley (on bearings), with the clamping screw at the rear, is almost in contact with the surface along which the flush cut is to be made. There should be a maximum of about 1 cm play between the flush surface and the guide pulley.

■ The pivoting guide pulleys should be positioned facing outwards at the beginning of the cut and should be free to pivot.

■ At the end of the cut, the pulleys will have pivoted to face inwards as they follow the course of the wire.

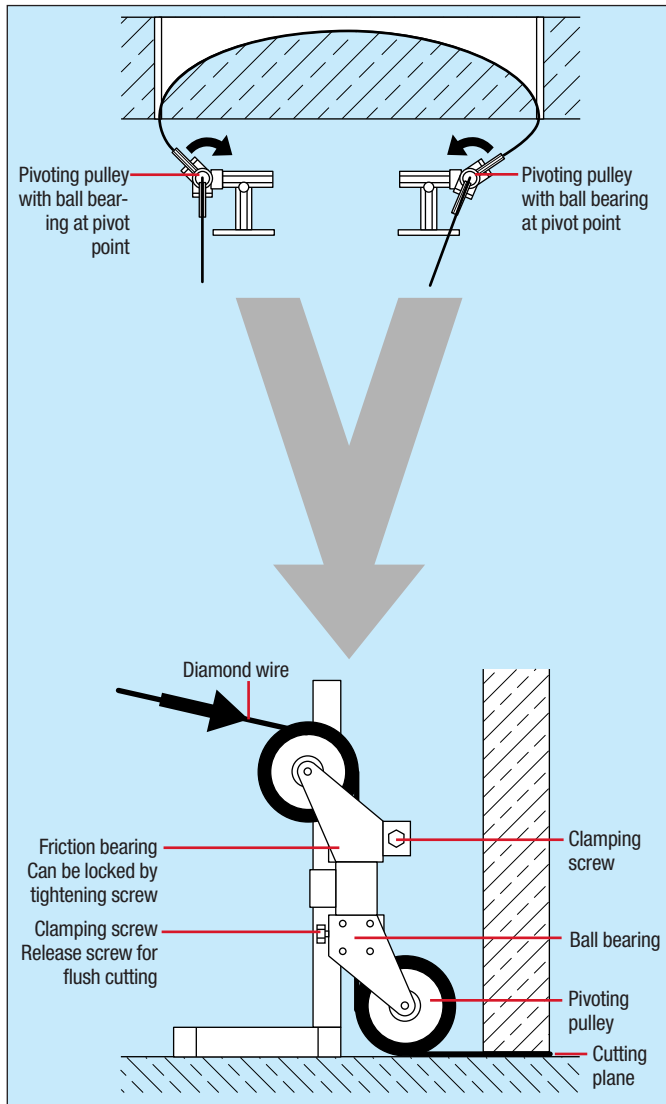

■ Guide pulley tube attached directly to the baseplate

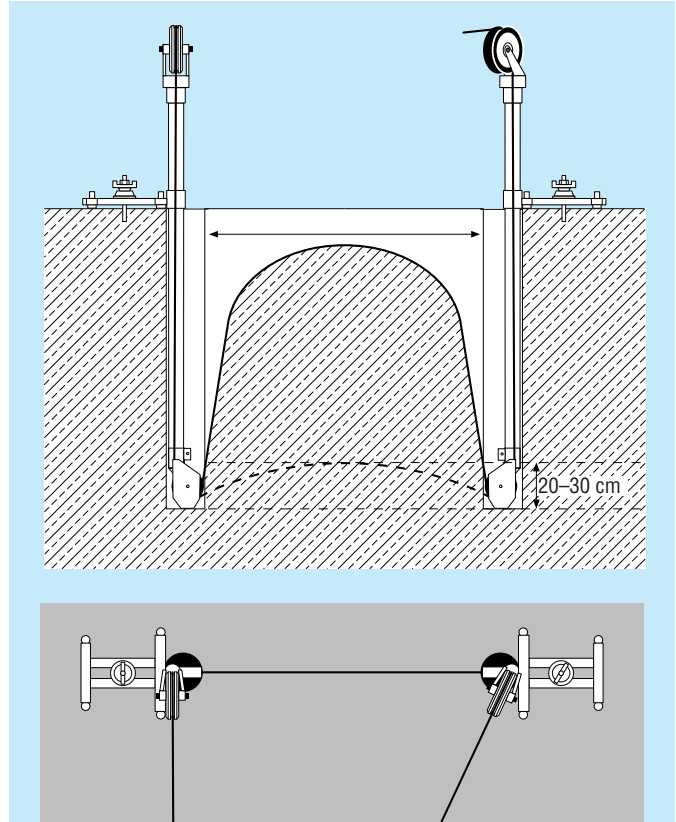

■ Guide pulley tube attached to the distance piece

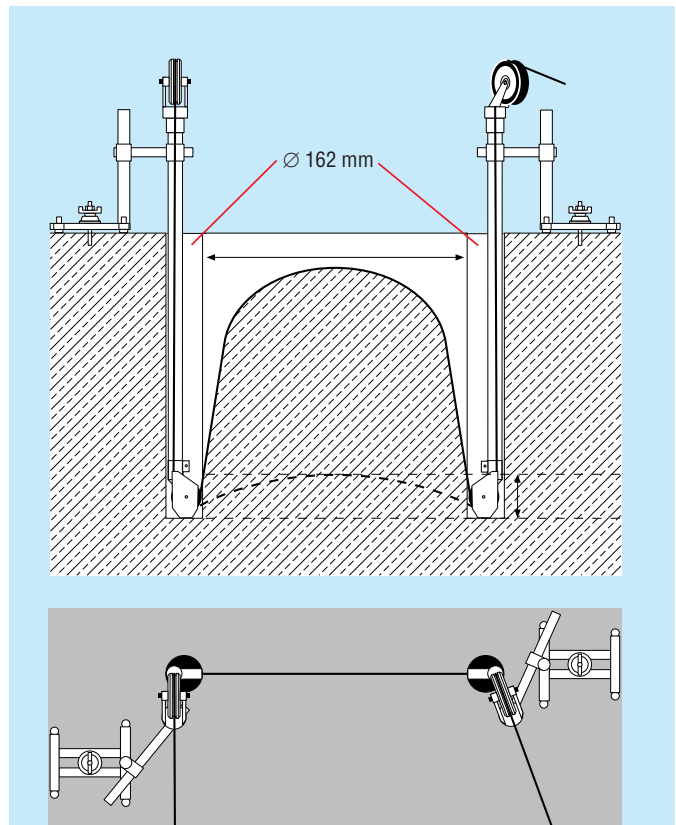

6.9.7 Using plunge pulleys

■ A plunge cutting application in a solid material is described.

■ For a cut of 2–3 m in length, the plunge pulleys must be set approximately 20 to 30 cm deeper because the end of the cut always takes the form of an arc.

6. Preparing the saw system for use

■ In so-called "external plunge" applications, the plunge pulleys are mounted on the outside of the object being cut. Cross-type tube clamps are used to mount the plunge pulleys on single-pair pulley stands. The time-consuming job of drilling through the object to be cut is thus no longer necessary.

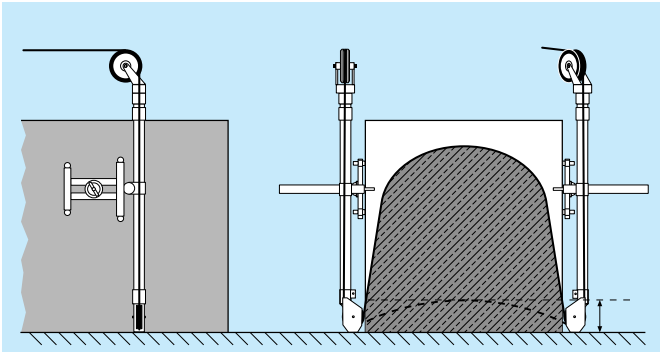

6.9.8 Using the DS-WSVC vertical cutting device

- No pulley stands are required for this type of cut.
- The drive unit is positioned directly on the object to be cut.
- Care must be taken to ensure that the drive unit and the guides for the wire to the object being cut are at right angles to each other. This can be adjusted by means of the height adjustment mechanism at the rear.

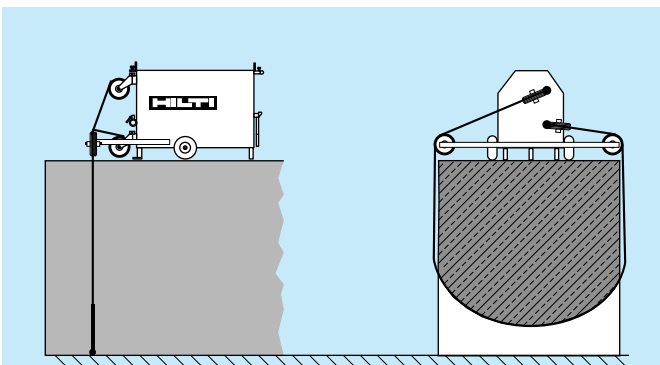

6.9.9 Assembly instructions DSW-WG wire guard

- The hazardous area may be entered only when the **EMERGENCY STOP** button is in the pressed-in position.
- Use the protective cover to augment the safety on your jobsite. NEVER enter the danger area while sawing is in progress.
- Mount the wire guard according to the assembly instructions below. It can be mounted after complete set up of the wire saw.

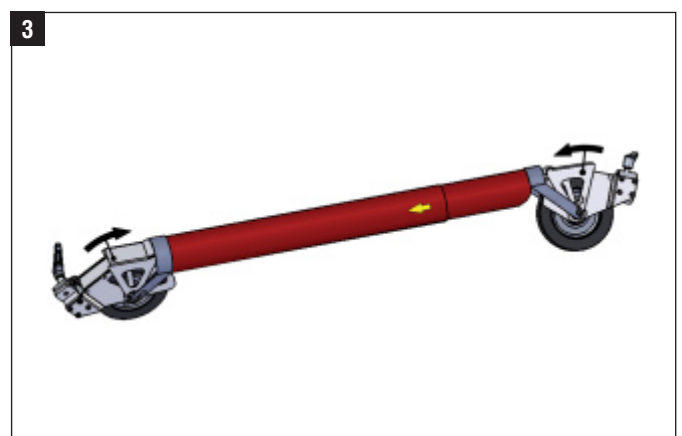
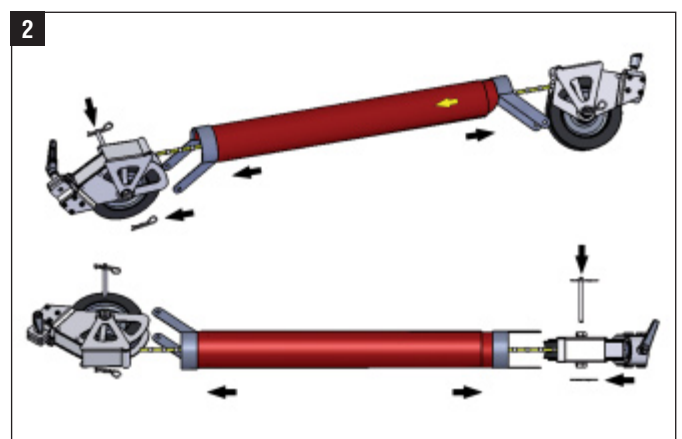
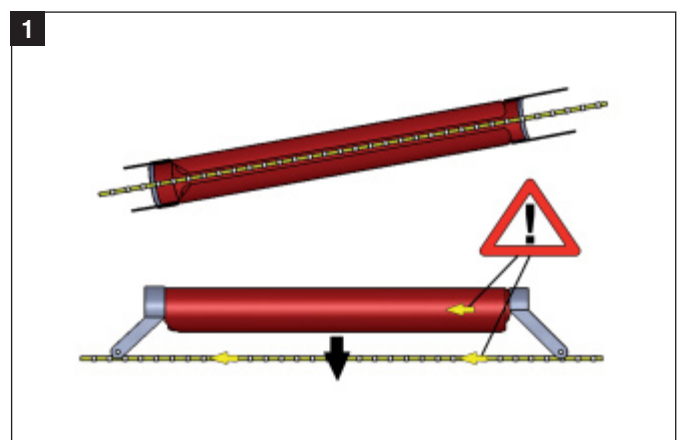
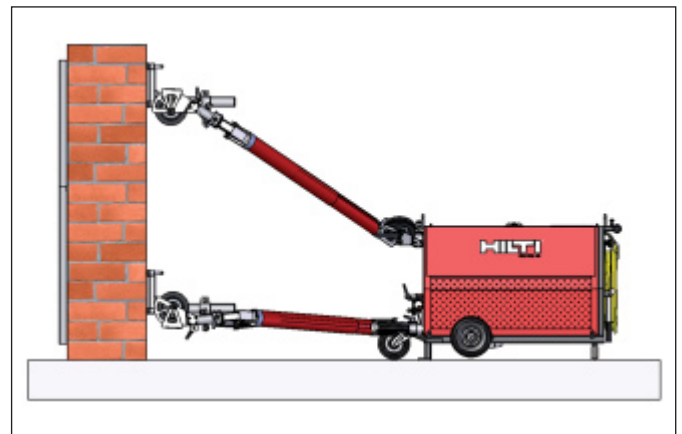



7. Operating the equipment

Operating the equipment	7.1 Checks prior to beginning sawing	40
	7.2 The starting procedure	40
	7.3 The sawing operation	40
	7.4 Ending the sawing operation	41

7. Operating the equipment

7.1 Checks prior to beginning sawing

- On-site preparatory work should be completed (supports, cordoning off the danger zone, arrangements for water collection etc.)
- The pulley stands and the drive unit should be correctly secured and the wire rigged on the saw in the correct direction of travel, the wire guard fitted, wire guidance on the pulleys checked and the guide pulleys tightened. The cooling water supply to the wire should have been installed.
- Electric power, compressed air and water should be connected. The power supply should be equipped with an earth/ground conductor and ground fault circuit breaker (PRCD) and should have been checked / tested. Water and compressed air supplies should be within the permitted pressure range.
- The control unit should be located outside the danger zone, hazardous areas in front of and behind the object to be sawn should have been checked and cordoned off and no persons should be present in the hazardous area.

7.2 The starting procedure

- Situation: The main switch is in the ON position. The “power” indicator light is green. The compressor and the system are pressurised. The advance lever is in the “sawing” (advance) position. The remaining switches are OFF or set at “0”.
- If necessary, when cutting masonry, the lower advance compressed air cylinder may be locked in position using the locking ring provided.
- Open the 2 water valves on the drive unit for the water supply to the cutting face.
- Adjust the advance pressure to approximately 1 bar at the control unit by means of the control knob (pulled out), or to the pressure recommended depending on the wire used for sawing.
- Switch on the water supply. The white indicator lamp lights.
- Switch on the drive (green “DS WS 15 Drive Unit” push-button).
- Use the speed regulator to increase speed gradually and, once the wire is running at a low speed (approx-

mately 3–10 m/s cutting speed), allow the wire to cut for a few seconds. Check that the wire is running correctly on all guide pulleys (max. 1 minute).

- By adjusting the speed regulator, accelerate the motors until the wire is running at the desired or, respectively, the optimum cutting speed.

Recommended cutting speeds (approximate)

Cutting method	Recommended cutting speed	Recommended wire length
Wet	Approx. 20–25 m/s	Keep wire as short as possible
Dry	Approx. 10–20 m/s	Long wire (assists cooling)

- Set the advance pressure (bar) so that current consumption is 25 – 30 amps. At 400 V it is possible to saw with only 16 amps, but only with greatly reduced cutting performance.
- Lock the compressed air control knob (press in).
- The DS WS 15 now continues sawing automatically. Monitor the cutting process. Normally, the saw has to be stopped for a short time soon after beginning cutting. Stop the saw by switching the drive OFF and then press in the EMERGENCY STOP button. Check the wire guidance and readjust the water supply.
- If necessary, release the locking ring on the compressed air cylinder.

7.3 The sawing operation

- Release the EMERGENCY STOP button and start the drive (the speed and pressure are already set and remain unchanged). The motors accelerate up to speed. The wire saw then cuts automatically.
- Monitor the sawing operation, paying particular attention to the cooling water supply to the wire. When wet sawing, the cooling water system must be readjusted as soon as dust is produced. In most cases, alignment of the guide pulleys also has to be changed approximately half-way through the cut.

Wire cooling

Cutting method	Cooling	Comments
Wet	Approx. 5 litres of water per min.	NO dust should be produced. Readjust water supply.
Dry	“Air cooling” - long wire	If necessary, use vacuum cleaner to remove dust at the wire exit point.

- The yellow warning lamp →I lights and the machine switches off. The drive carriage has reached the end of its travel, i. e. is at the advance end stop. Press the dri-

ve OFF and the EMERGENCY STOP buttons. Stop the flow of cooling water.

- Remove the protective cover from the drive unit and bring the travelling drive motor into the forward drive position either manually or using the compressed air control system.

- Wind the slack wire onto the storage pulleys. The second operator ensures that the wire is correctly positioned on the pulleys. Re-adjust the hollow axle of the guide pulleys at the tension side to bring it into alignment with the wire entering the store and tighten the clamping screw. Replace the protective cover.

- Should the wire store offer insufficient capacity during extreme applications, simply move the drive unit back a distance of 1–2 metres and then re-secure it in its new position.

- Check the alignment of the guide pulleys and readjust if necessary.

- Reset the advance pressure to the recommended value in accordance with the table. Lock the compressed air control knob again and switch on the cooling water system.

- Disengage the EMERGENCY STOP button and press the drive ON button. Use the speed control knob to accelerate gently to the desired or optimum cutting speed. The DS WS 15 then saws automatically.

- Monitor the sawing operation. If the saw wire vibrates excessively, check the alignment of the pivoting or guiding pulleys. If necessary, adjust the wire speed and advance pressure slightly.

- **Important:** Press the EMERGENCY STOP button in the event of a critical or dangerous, unforeseen situation developing while sawing, e.g. a wire jumping off a guide pulley or a person entering the danger area unexpectedly. The drive unit then switches off.

- Closely observe sawing progress and pay attention to the guide pulleys. Switch off the machine and pivot the guide pulleys through 180° in good time - before the wire begins to cut into the hollow axle between the pulleys!

- Adequate cooling water and round, gentle cutting arcs are the decisive factors in achieving good cutting results in terms of cutting speed, safety and wire life.



- **The drive unit must be switched off and the EMERGENCY STOP button pressed before readjusting the water supply, swivelling the guide pulleys, winding wire onto the storage pulleys and before cleaning parts.**

- When switching the drive unit off temporarily (e.g. when adjusting the water supply etc.) do not alter the previously set parameters such as drive speed and advance pressure (compressed air set at 1.5 bar, for example). These operating controls can remain at the previous settings.

7.4 Ending the sawing operation

- Towards the end of the cut, the arc followed by the wire becomes increasingly flat, sawing efficiency drops and the tension on the wire increases. If necessary, the guide pulleys can then be mounted at the end of the pulley stand, further away from the object being cut.

- Prior to completing the cut and sawing right through, ensure that the part of the object being cut (or being cut free) is secured so that it cannot move or will move in the desired direction. If necessary, use steel wedges to secure the object temporarily.

- Reduce the speed of the wire considerably during the final cutting phase. In normal circumstances, the wire will be caught by the guide pulleys, without jumping off. Switch off the drive unit after the object has been sawn through.

- Set all operating controls on the control unit to the OFF or NEUTRAL positions and press the EMERGENCY STOP button. The main power switch may be left in the ON position and the electric supply cable should remain connected.

- Immediately after completing the cut, wash down the pulley stands and the guide pulleys mounted at the object cut and on the drive unit by spraying the parts with water, paying special attention to the guide pulleys and wire storage section.



Care and maintenance	8.1 Cleaning the wire saw	44
	8.2 Care and maintenance	44
	8.3 Wearing parts	45
	8.4 Service and repair	45
	8.5 Electrical circuit diagram – control unit	46
	8.6 Electrical circuit diagram – drive unit	47
	8.7 Pneumatic circuit diagram – drive unit	48

8. Care and maintenance

8.1 Cleaning the wire saw

CAUTION

Disconnect the supply cord plug from the power outlet.

CAUTION

Keep the machine, especially its grip surfaces, clean and free from oil and grease. Do not use cleaning agents which contain silicone.

■ We recommend that the most important parts of the wire saw are cleaned quickly between each cut made. Simply hose down the guide pulleys, the pulley stands and the front as well as the wire storage section of the drive unit.

■ All operating controls should be switched to the OFF or NEUTRAL position prior to more thorough daily cleaning of the equipment. Switch off the main switch at the control unit and disconnect the power supply plug.

■ Wash down the complete set of equipment at the end of each working day using a hose and brush, paying special attention to the parts mentioned above. The cleaning operation should be part of your daily work schedule and ensures that you will be able to work efficiently each day. If the equipment is left uncleaned even for only one night, the guide pulleys and moving parts will become stuck with hardened concrete slurry which will then have to be removed in a tedious, time-consuming process, with a risk of causing damage to the parts.

■ Do not hose down the control unit, simply wipe it clean with a damp cloth. Use of a high-pressure steam cleaning system is not permissible!

■ After cleaning the equipment, check the guide pulleys and moving parts for ease of movement. Inspect the parts to ensure they are in good condition and the controls are in good working order. Damaged or malfunctioning parts must be replaced immediately in order to avoid accidents or further costly damage.

■ At temperatures below zero ($-^{\circ}\text{C}$), the cooling water must be blown out of the motors after work or cleaning is complete (open one of the two water taps at the front and direct compressed air into the drive **1** unit water supply connector **2**). Blow through until all water is forced out.

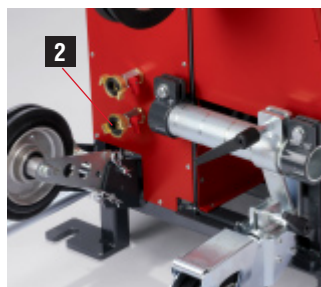
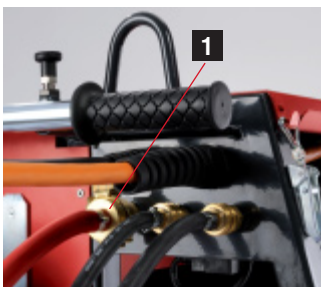

8.2 Care and maintenance

■ Clean and oil all moving parts after use and, from time to time, use a grease gun to grease the bearings of the guides on the guide rods (see photo **1**). This prevents water and dirt entering the bearings and thus avoids unnecessary wear.

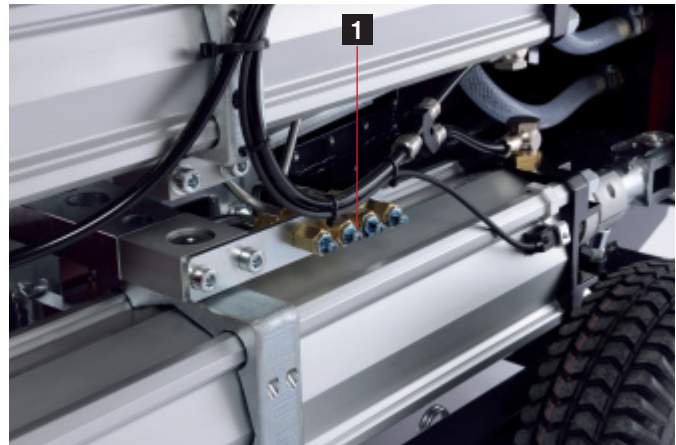

■ Check the condition of the air filter occasionally **2**. It is located in the top right-hand section of the control unit and should be cleaned or replaced as necessary.



8.3 Wearing parts

■ A list of the most important consumables and wearing parts is provided in Section 3 and in the tools / accessories brochure. Certain parts such as guide pulleys, drive wheels and water supply nozzles can also be found in the brochure. Please contact your Hilti representative if you require parts.

8.4 Service and repair

■ Malfunctions are unlikely to occur as long as the equipment is kept clean and well lubricated. Dirty parts and incorrect operation lead to malfunctions.

■ The mechanical design of the wire saw system has been kept very simple. With the aid of the consumables items and wearing parts supplied by Hilti, the operator is in a position to maintain and service the mechanical parts of the system himself by replacing items such as guide pulleys or connectors etc.

■ Other parts (spare parts) are available as necessary from the service department and can usually be fitted on-site by the operator himself or by a Hilti diamond systems specialist or Hilti mechanic.

■ It may happen, for various reasons, that one of the fuses in the control unit blows.

■ All fuses are available commercially and a spare set of fuses is provided inside the control unit. The fuses in the control unit can be replaced by the operator. Please refer to the “Accessories” and “Fault Finding” sections.

■ Repairs or adjustments to electrical components (e.g. to the current converter) may be carried out only by appropriately trained and qualified specialists. Instructions applicable to the current converter are provided inside the control unit.

8. Care and maintenance

8.5 Electrical circuit diagram – control unit

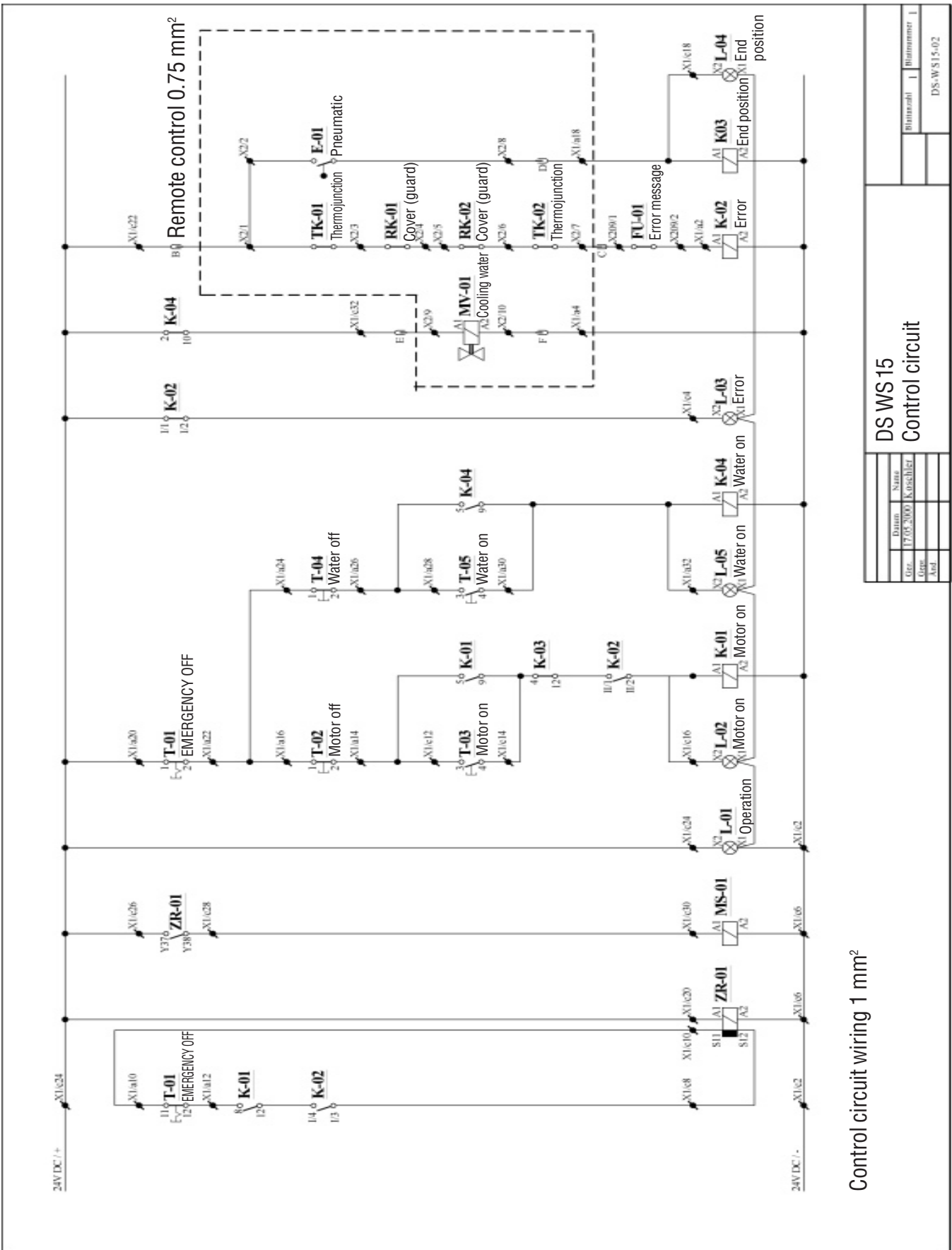

8.6 Electrical circuit diagram – drive unit

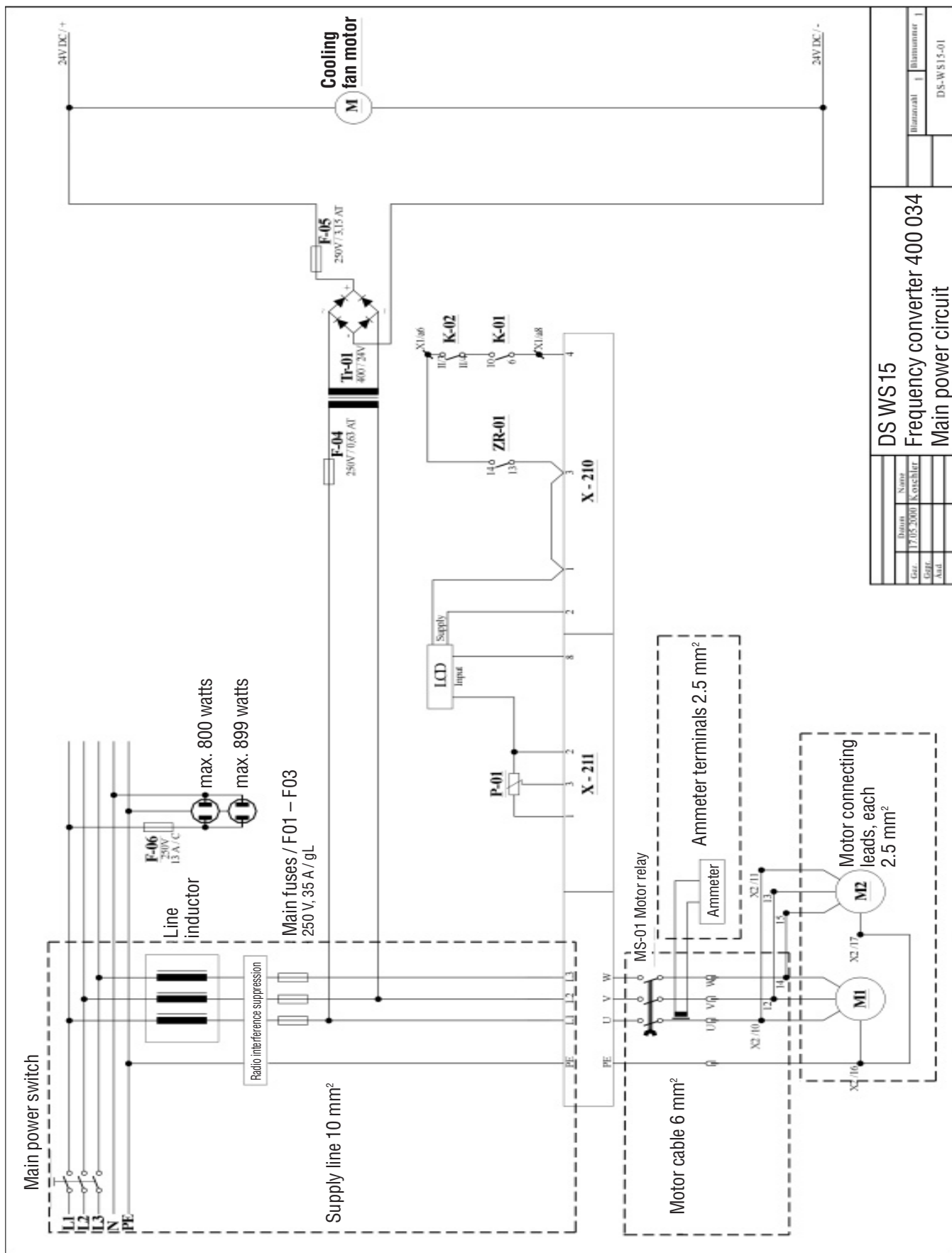

8. Care and maintenance

8.7 Pneumatic circuit diagram – drive unit

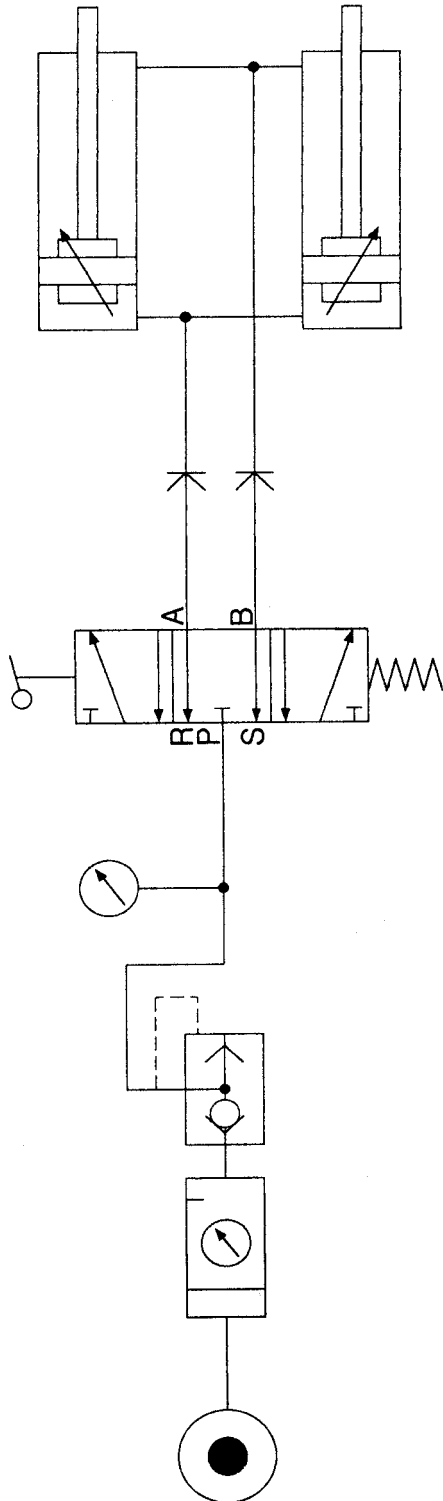

Verwendungsbereich	Mafstab 1:1		Gewicht
	Verstärker		
Firmalieferanz DIN g	Oberfläche		Benennung Pneumatic circuit diagram
	Name		
	P.D.		
	Datum		
Zust.	Bearb. 8.10.00		Zeichnungsnummer P90112-A
	Gepr.		
	Norm		
Änderung		Ers. d.	
Datum		Name	
Uvr.		Blatt	

Troubleshooting	9.1 Problems or faults concerning the diamond wire	50
	9.2 Remediating DS WS 15 wire saw system malfunctions	53

9. Troubleshooting

Persons may enter the danger zone only when the drive unit is switched off and the drive pulley has stopped rotating. Press the EMERGENCY STOP button before entering the danger zone.

Disconnect the equipment from the electric supply (unplug the supply cord from the power outlet) before opening the control unit.

9.1 Problems or faults concerning the diamond wire

■ The DS WS 15 cannot start movement of the wire

Possible cause	Solution / measures
Edges of the concrete are too sharp.	– Use a Hilti combihammer to round the edges and pull the diamond wire back and forward by hand before starting.
A new diamond wire sticks in the kerf cut by a worn wire.	– Complete the cut with the worn wire. – Mount additional return pulleys or release pulleys.
The length of contact between the diamond wire and the concrete is excessive.	– Drill a hole through which the new wire can be threaded.
Tension on the diamond wire is too high.	– Reduce wire tension by adjusting the air pressure regulation valve.

■ The diamond wire slips on the drive wheels

Possible cause	Solution / measures
Insufficient tension on the diamond wire	– Increase the tension by adjusting the air pressure regulation valve.
The rubber tyre on the drive wheel is worn excessively.	– Replace the drive wheel.

■ The wire jumps off the drive wheels when starting

Possible cause	Solution / measure
The starting lock was not used.	– Use the starting lock (position and lock the clamping piece against the air cylinder).

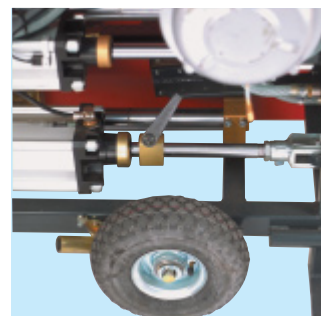

■ Irregular, one-sided wear of the diamond wire

Possible cause	Solution / measures
The diamond wire was not twisted before connecting the ends together.	<ul style="list-style-type: none"> – Twist the diamond wire approx. 1-1.5 turns to the left, as seen when looking at the cut face of the wire. – The wire must be re-twisted after each large cut, applying a different number of turns for each cut (more turns or fewer turns, alternately).

■ Wire breakage directly after the connector

Possible cause	Solution / measures
Cutting radius of the diamond wire in the concrete is too tight.	– Mount additional return pulleys.
Wire connector is too long.	<ul style="list-style-type: none"> – Fit shorter wire connector. – Use the quick-release connectors recommended by Hilti instead of rigid connectors.

■ The diamond wire pulls out of the crimped connector

Possible cause	Solution / measures
Incorrectly adjusted crimping pliers	– Check how the crimping pliers are set.
Insufficient pressure applied to the crimping pliers	– Minimum crimping pressure is 7 t (Hilti crimping pliers = 8 t)
Incorrect or worn crimping jaws	– Check the crimping jaws and replace if necessary.
The wire was not pushed far enough into the connector.	– The wire must always be pushed into the connector as far as it will go. The end of the wire must be cut cleanly and in accordance with instructions.

■ The diamond wire jumps about and vibrates very strongly

Possible cause	Solution / measures
Insufficient tension on the wire	– Increase the wire tension by adjusting the air pressure regulation.
Guide pulleys are too far apart (free length of wire is too long).	<ul style="list-style-type: none"> – Mount additional pulley stands. – Fit a shorter diamond wire. – Position the drive unit closer to the object being cut.

■ The diamond wire vibrates very strongly at a high frequency

Possible cause	Solution / measures
Tension on the wire is too high.	– Reduce the tension on the wire by adjusting the air pressure regulation.
The saw is running at the wrong speed.	– Set the correct speed.

9. Troubleshooting

■ The diamond wire wears too quickly

Possible cause	Solution / measures
Drive speed is too low and wire cutting speed is thus also too low.	– Increase drive speed or, respectively, cutting speed.
Inadequate cooling of the diamond wire	– Set up more water nozzles at the cutting face.
Wire cutting length too short (length of contact between the wire and the concrete)	– Increase the cutting length (length of contact).
Wire tension too high relative to length of cut.	– Reduce the tension on the wire by adjusting the air pressure regulation valve.
Very abrasive material being cut.	– Select a different diamond wire specification.
The direction in which the wire runs is changed continually.	– Always fit the diamond wire so that it runs in the same, specified direction.

■ The diamond wire collapses

(The diamond beads, connecting pieces and separating springs are bunched together on the wire.)

Possible cause	Solution / measures
Diamond wire not cooled adequately or not cooled at all	– Always ensure that sufficient water reaches the cutting face.
The diamond wire becomes stuck in the kerf and stalls during sawing.	– Steel wedges must be used to prevent movement of the concrete sections. – Loose fragments or aggregates must be removed from the kerf.

9.2 Remedying DS WS 15 wire saw system malfunctions

- The DS WS 15 doesn't start.
The main switch is in the ON position but the green "ready for operation" lamp doesn't light.

Possible cause	Solution / measures
No power supplied by the cable.	<ul style="list-style-type: none"> – Check the mains fuse at the switchbox (35–40 A)
Voltage of one phase is too low or missing completely.	<ul style="list-style-type: none"> – Check the 3 phases individually. – Check the extension cable and plugs / sockets for faults or loose contacts. – Call in the jobsite electrician.
Fuse blown or circuit breaker tripped at the switchbox.	<ul style="list-style-type: none"> ■ Replace blown fuses or reset the circuit breaker. – Mains fuse 1 – Transformer fuse 3.15 A, slow 2 – Transformer fuse 0.63 A, slow 3 – 1 relay unit for 4, 5, 6 – Spare fuses are provided in the control unit. 1 2 3 4

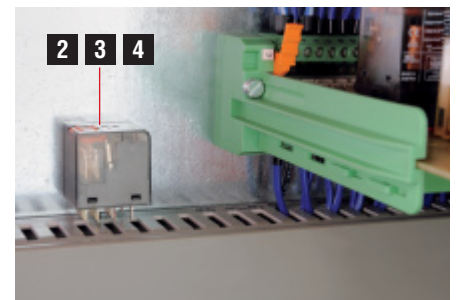

■ Fault with one of the following symptoms

Possible cause	Solution / measures
① Red lamp on left doesn't light, converter/drive motors not running.	– Swap or replace relay 4 .
② Red lamp at middle left doesn't light, problem with thermal circuit breaker, wire guard.	– Call in an electrical specialist, relay 7
③ Red lamp at middle right doesn't light, pneumatic advance at end stop	– Swap or replace relay 5 .
④ Red lamp on the right lights, water valve	– Swap or replace relay 6 .

The same type of relay **4, 5, 6** is used for ①, ③ and ④, i. e. they can be swapped with each other.

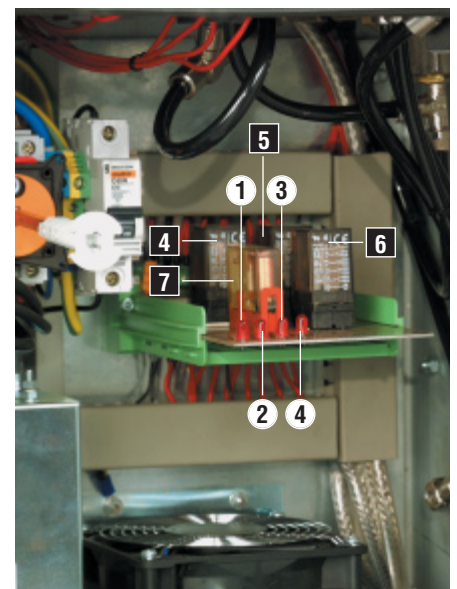

9. Troubleshooting

- **The DS WS 15 doesn't start.**
The green “ready for operation” lamp lights together with the red “error” lamp.

Possible cause	Solution / measures
Power cable or control cable from the drive is not connected to the control unit.	– Connect the cables.
The protective cover is not fitted on the machine 5	– Fit the protective cover.
The motors are too hot.	– Use more cooling water or colder water.
The current converter is overloaded.	– Do not work at above 30 A. – Check the filter in the base of the control unit (a flow of air must be felt at the top opening on the control unit).

Resetting the converter:
Switch off at the main switch and wait approx. 1 minute before switching on again.



- **The DS WS 15 doesn't start.**
The green “ready for operation” lamp lights.

Possible cause	Solution / measures
The EMERGENCY STOP button is pressed in.	– Release the EMERGENCY STOP button.

- **The DS WS 15 cuts out while running and cannot be restarted.**
The green “ready for operation” lamp lights together with the yellow “pneumatic advance” lamp.

Possible cause	Solution / measures
The air cylinders and carriage are in the end position.	– Reduce the wire length (wind onto the storage pulleys) or move the machine back.

■ No voltage at the 230 V socket

Possible cause	Solution / measures
Neutral conductor not connected.	– Check connections and the power supply.
Circuit breaker tripped.	– Reset the circuit breaker 6 .



■ High current input (more than 40 A) or the converter is overloaded.

Possible cause	Solution / measures
Wire tension is too high.	– Reduce the tension by adjusting the air pressure regulating valve 7 .



10. Disposal DS WS 15



Return waste material for recycling

Most of the materials from which Hilti appliances are manufactured can be recycled.

The materials must be correctly separated before they can be recycled.

Hilti has already made arrangements in many countries for taking back your old appliance for recycling. Please ask your Hilti customer service department or a Hilti sales representative for further information.



Only for EU countries

Do not dispose of electric tools together with household waste material!

In observance of European Directive on waste electrical and electronic equipment and its implementation in accordance with national law, electric tools that have reached the end of their life must be collected separately and returned to an environmentally compatible recycling facility.

11. Manufacturer's warranty – tools

Please contact your local Hilti representative if you have questions about the warranty conditions.

12. EU declaration of conformity (original)

12.1 Noise and vibration levels

Noise information (as per EN ISO 3744)

Appliance: DS WS 15 electric wire saw

Typical A-weighted sound pressure level
at the operating position at a
distance of 2.8 m from the drive unit: 79 dB(A)

The operator is NOT required to wear ear protection.

12.2 EU declaration of conformity (original)

Description: Electric wire saw

Serial nos.: 403 up to 9999

Designation: DS WS 15

Year of design: 2000

We declare under our sole responsibility that this product complies with the following directives and standards:
19th April 2016: 2004/108/EC, from 20th April 2016: 2014/30/EU, 2006/42/EC, 2011/65/EU, EN 60204-1,
EN 12100.

This equipment complies with the applicable standard provided that the short-circuit power S_{SC} at the interface point between the user's supply and the public supply network is greater than or equal to 3.2 MVA. It is the responsibility of the installer or user of the equipment to ensure, by consultation with the supply network operator if necessary, that the equipment is connected only to a supply with a short-circuit power S_{SC} of greater than or equal to 3.2 MVA.

Hilti Corporation, Feldkircherstrasse 100, FL-9494 Schaan



Paolo Luccini

Head of BA Quality and Process Management
Business Area Electric Tools & Accessories

06 / 2015



Johannes Wilfried Huber

Senior Vice President
Business Unit Diamond

06 / 2015

Technical documentation filed at:

Hilti Entwicklungsgesellschaft mbH
Zulassung Elektrowerkzeuge
Hiltistrasse 6
86916 Kaufering
Deutschland



Hilti Corporation
LI-9494 Schaan
Tel.: +423 / 234 21 11
Fax: +423 / 234 29 65
www.hilti.com



339276