

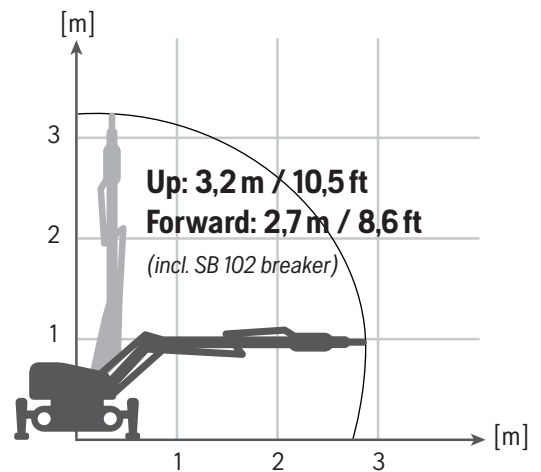

HUSQVARNA DXR 95

COMPACT AND POWERFUL DEMOLITION ROBOT

Now you can do more – a lot more – in less space. Compact and portable, the new DXR 95 brings pure demolition power to all kinds of confined areas – from narrow passageways to tight crawl spaces, and even steep inclines. When it comes to boosting your productivity, the DXR 95 is a demolition robot that delivers maximum impact.



FEATURES



SMALL FOOTPRINT

The DXR 95 fits in an ordinary van – perfect for construction and industrial applications.



HEAVY-DUTY ARM SYSTEM

The arm is robust, strong and durable yet low in weight.



SUPERB POWER-TO-WEIGHT RATIO

Compact and powerful, yet low in weight.



PROTECTION OF VITAL PARTS

The electric motor, hoses and cables are protected by the robust lower chassis.

FEATURES



SUPERIOR REMOTE CONTROL

Provides a satisfying user experience and excellent, intuitive operational control.

AUTOMATIC GREASING

No need to manually grease the breaker, which means longer service intervals and longer operational life.

EASY ACCESS FOR SERVICE

The covers on the main body are easy to open and detach for fast service.

EXCELLENT THERMAL MANAGEMENT

The oil cooler has a dedicated fan for improved performance.

THIRD-PARTY CERTIFIED

All models are third-party certified regarding EMC and the EU Machinery Directive.

POWERFUL ILLUMINATION

Exceptionally bright LED lights improve visibility and boost worksite efficiency.

MANAGES STEEP INCLINES

Handles a high degree of tilt, with a maximum slope angle of 30°.

SPECIFICATIONS DXR 95

Art.no: 970 69 69-01 (50 Hz). 970 69 69-03 (60 Hz).

GENERAL

Max. transport speed, km/h / mph	3/1.9
Max. slope angle, degrees	30

HYDRAULIC SYSTEM

Volume hydraulic system, l/gal	30/6
Max. pump flow ¹ , l/min or gal/min	0-32 or 0-8.5
Standard pressure, bar	180
Increased main pressure, bar	250

WEIGHT

Product weight with rubber caterpillar track, without tool, kg/lbs	589/1298.5
--	------------

MOTOR

Motor power, kW/Hz	9.8/60
Speed, rpm/Hz	1700/60
Rated voltage, V/Hz	440-480/60
Rated current, A/Hz	15/60

DIMENSIONS

Width, length, height cm/in	922, 1510, 887 / 36.3, 59.4, 34.9 ²
-----------------------------	--

¹ Maximum pump flow and system pressure cannot be used at the same time. It can cause overload of the motor. 60 Hz has limited displacement.

² Inc. breaker SB 102.

RELATED PRODUCTS AND ACCESSORIES



BREAKER SB 102

Art.no: 546 22 06-01
Impact energy: 159 J/ 117 ft/lbs.
Impact Frequency: 38 Hz.
Weight: 110 kg/243 lbs.



BREAKER SB 52

Art.no: 546 22 16-01
Impact energy: 101 J/ 75 ft/lbs.
Impact Frequency: 28 Hz.
Weight: 72 kg/159 lbs.



CONCRETE CRUSHER DCR 90

Art.no: 546 42 43-01
Jaw opening: 270 mm/10.6 in.
Crushing Force: 24 t.
Weight: 94 kg/207 lbs.



BUCKET DXR 95 | 45 | STANDARD

Art.no: 546 29 97-01



BUCKET DXR 95 | 30 | NARROW

Art.no: 546 29 97-02

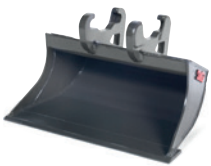

BUCKET DXR 95 | 45 | WIDE

Art.no: 546 29 97-03



DRUM CUTTER ER 40

Art.no: 546 22 20-01
Cutting width: 400 mm/15.7 in.
Weight: 107 kg/236 lbs.



GRAPPLER MG 100

Art.no: 586 74 29-02
Jaw opening: 600 mm/23.6 in.
Volume: 30 l/7.9 gal.
Weight: 82 kg/181 lbs.



DUST REDUCTION KIT DXR 95

Art.no: 536 11 20-05



DUST REDUCTION KIT SB 52, SB 102 & ER 40

Art.no: 583 80 72-03



DUST REDUCTION KIT DCR 90

Art.no: 596 52 82-02



TOOL DRAIN KIT

Art.no: 583 80 73-05



EXTRA HYDRAULIC FUNCTION

Art.no: 536 11 24-05



husqvarnaconstruction.com